

Good Bye

TORNADO

F.3 ADV

1/48



eduard

LIMITED EDITION

ATTENTION



UPOZORNĚNÍ



ACHTUNG



ATTENTION



注意



Carefully read instruction sheet before assembling. When you use glue or paint, do not use near open flame and use in well ventilated room. Keep out of reach of small children. Children must not be allowed to suck any part, or pull vinyl bag over the head.



Před započatím stavby si pečlivě prostudujte stavební návod. Při používání barev a lepidel pracujte v dobře větrané místnosti. Lepidla ani barvy nepoužívejte v blízkosti otevřeného ohně. Model není určen malým dětem, mohlo by dojít k požití drobných dílů.

INSTRUCTION SIGNS

* INSTR. SYMBOLS

* INSTRUKTION

* SINNBILDEN

* SYMBOLES

* 記号の説明

OPTIONAL
VOLBABEND
OHNOUTSAND
BROUSITOPEN HOLE
VYVRTAT OTVORSYMETRICAL ASSEMBLY
SYMETRICKÁ MONTÁŽREMOVE
ODŘÍZNOUTREVERSE SIDE
OTOČITAPPLY EDUARD MASK
AND PAINT
POUŽIT EDUARD MASK
NABARVIT

PARTS



DÍLY



TEILE



PIĘCES



部品

PLASTIC PARTS

A>

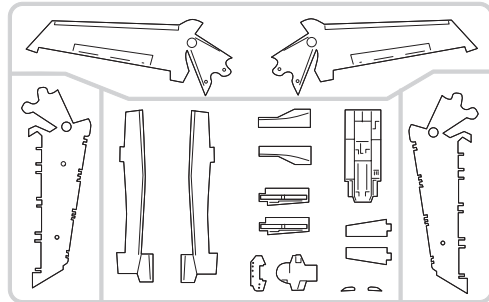

B>

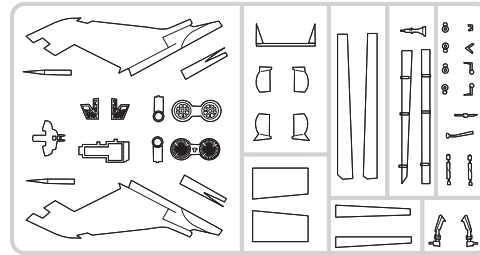

C>

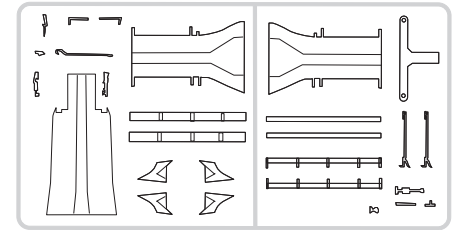

D> 2 pcs.

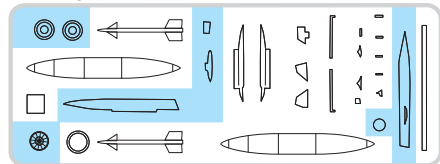

E> 2 pcs.

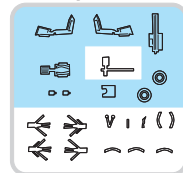

F>

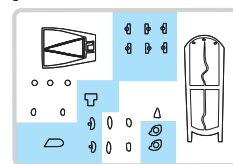

H> 2 pcs.

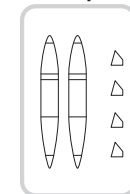

I> 2 pcs.

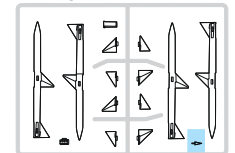

M>

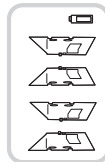

S>

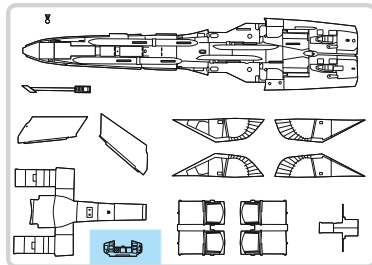

P>

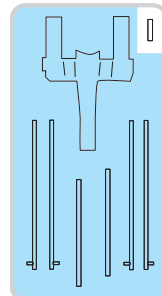

R>

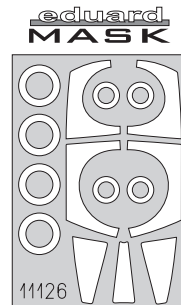
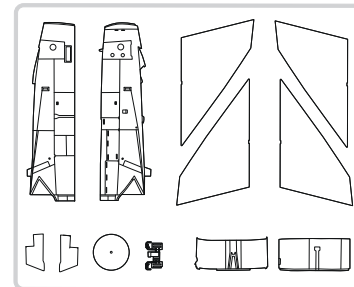

PE - PHOTO ETCHED DETAIL PARTS

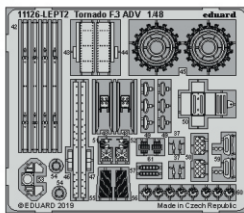
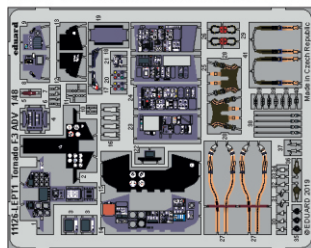

RP - RESIN PARTS



R1 2pcs.



FILM



1. This part is not for use. This version must be removed. -Tyto díly nepoužívejte při stavbě. - 使用しない部品

COLOURS



BARVY



FARBEN



PEINTURE



色

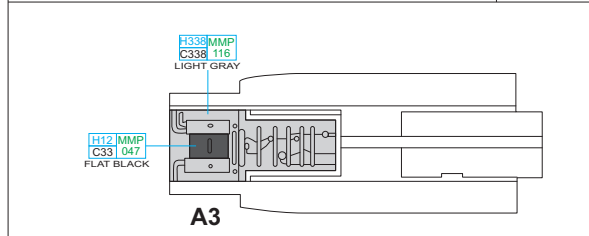
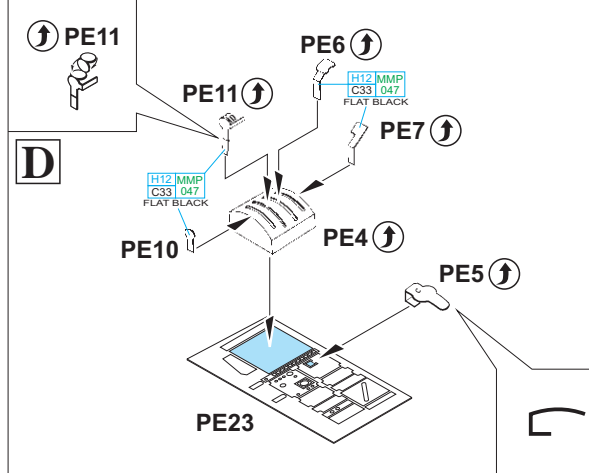
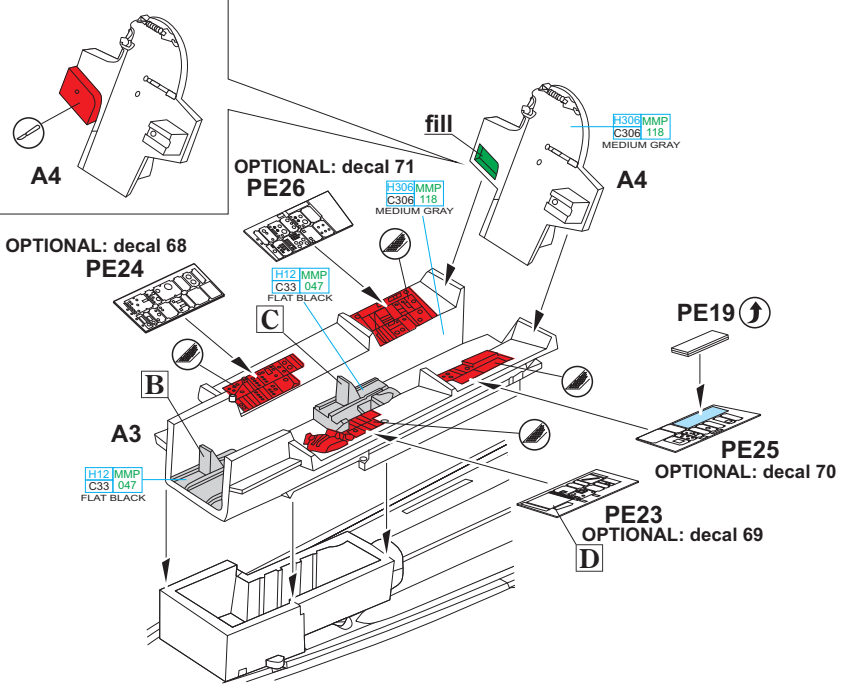
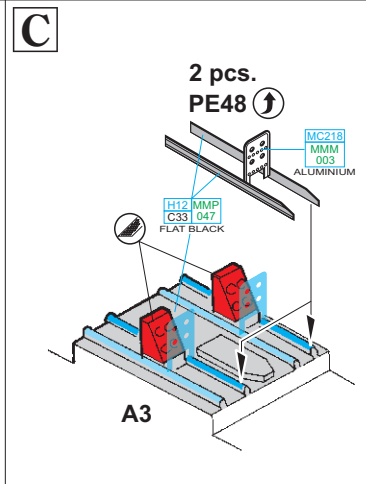
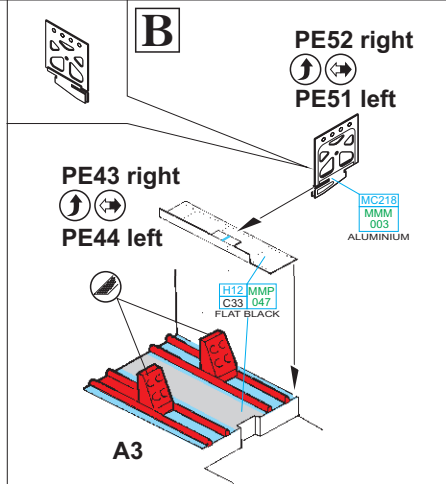
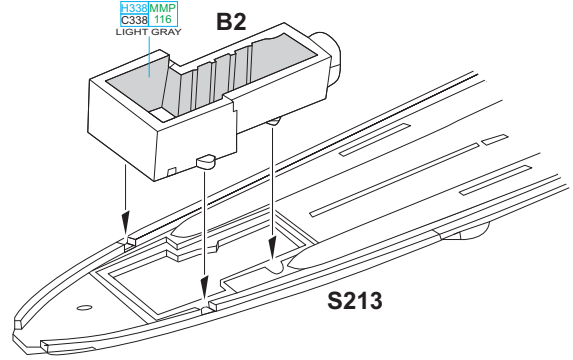
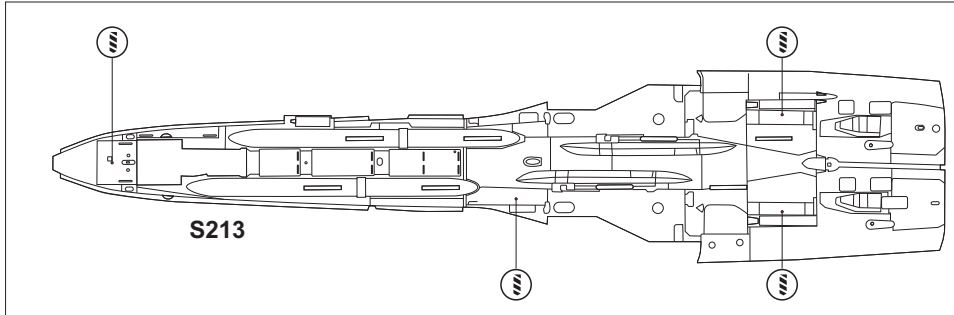
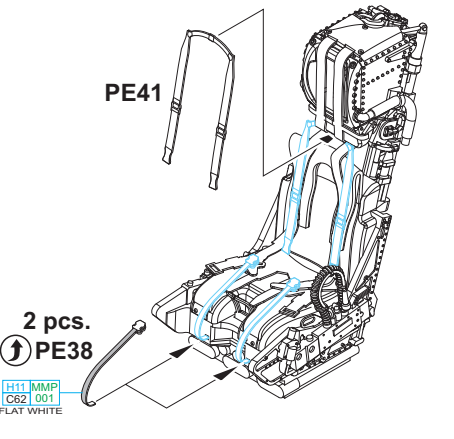
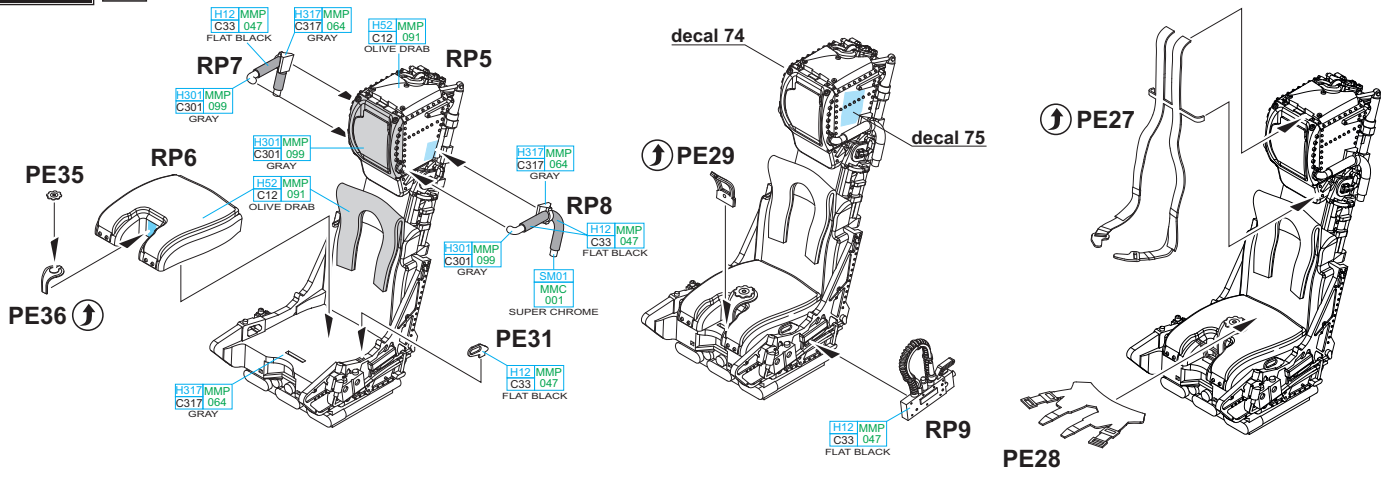

GSI Creos (GUNZE)		MISSION MODELS	
AQUEOUS	Mr.COLOR	PAINTS	
H4	C4	MMP-007	YELLOW
H11	C62	MMP-001	FLAT WHITE
H12	C33	MMP-047	FLAT BLACK
H27	C44		TAN
H52	C12	MMP-091	OLIVE DRAB
H77	C137	MMP-040	TIRE BLACK
H90	C47		CLEAR RED
H94	C138		CLEAR GREEN
H301	C301	MMP-099	GRAY
H306	C306	MMP-118	MEDIUM GRAY
H317	C317	MMP-064	GRAY
H327	C327	MMP-101	RED
H331	C331		DARK SEAGRAY

GSI Creos (GUNZE)		MISSION MODELS	
AQUEOUS	Mr.COLOR	PAINTS	
H332	C332		LIGHT AIRCRAFT GRAY
H334	C334	MMP-102	BARLEY GRAY
H335	C363	MMP-094	MEDIUM SEAGRAY
H338	C338	MMP-116	LIGHT GRAY
Mr.METAL COLOR		METALLICS	
MC213		MMM-006	STEEL
MC214		MMM-001	DARK IRON
MC218		MMM-001	ALUMINIUM
Mr.COLOR SUPER METALLIC		METALLICS	
SM01		MMC-001	SUPER CHROME
Mr.COLOR GX		METALLICS	
GX02			UENO BLACK

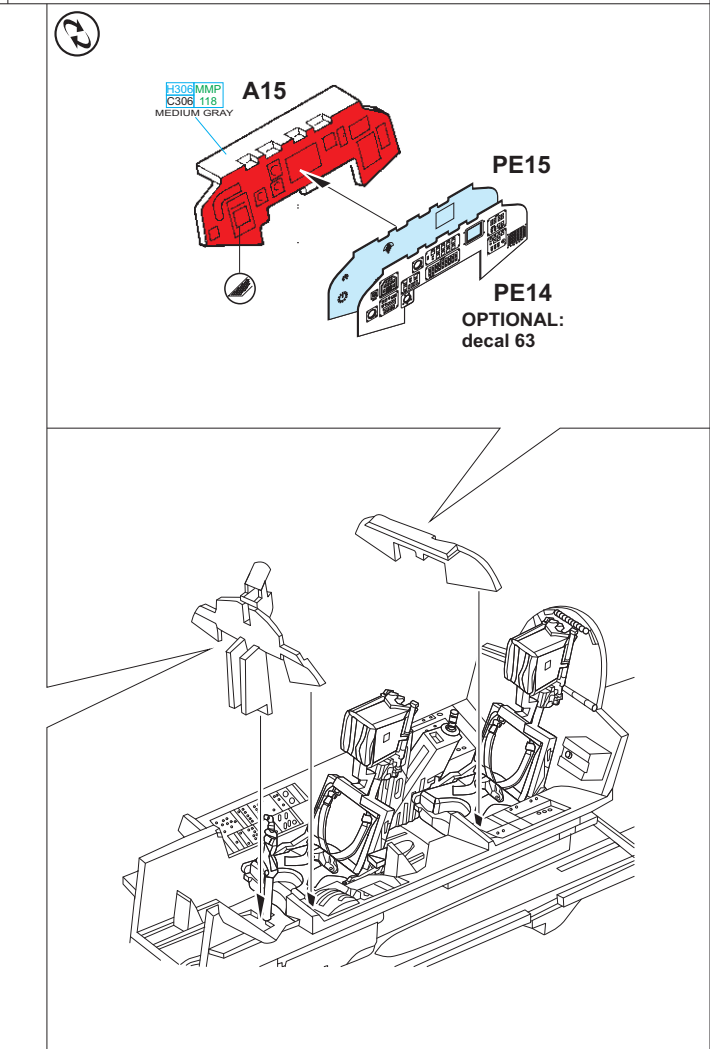
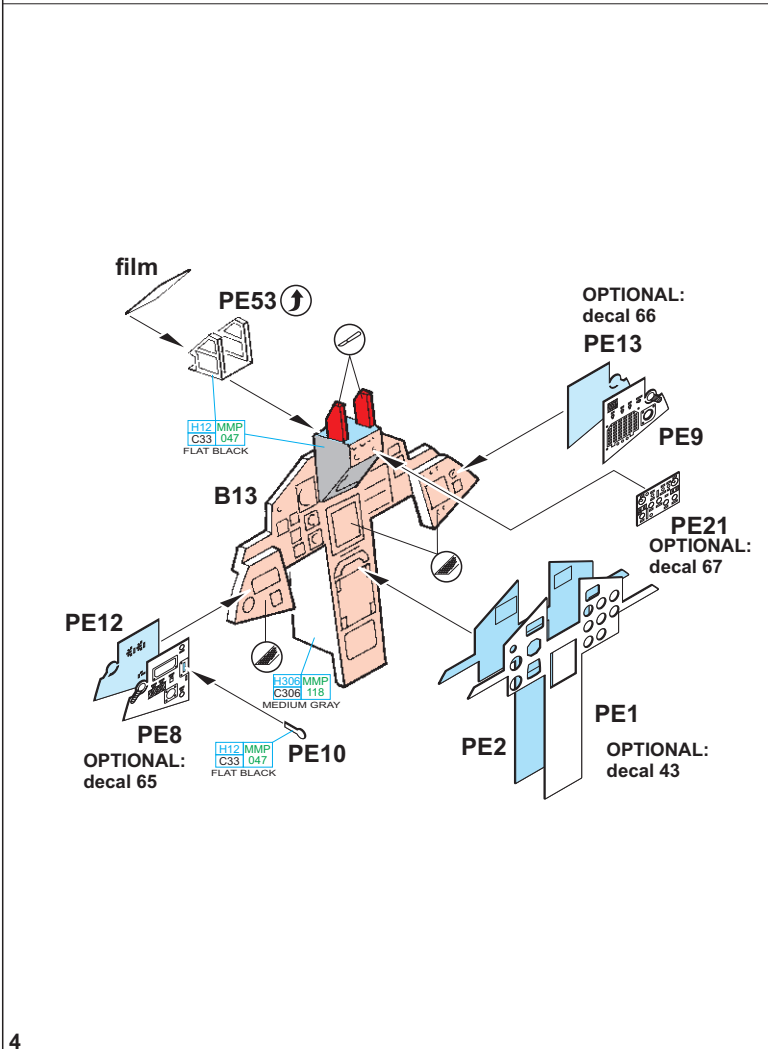
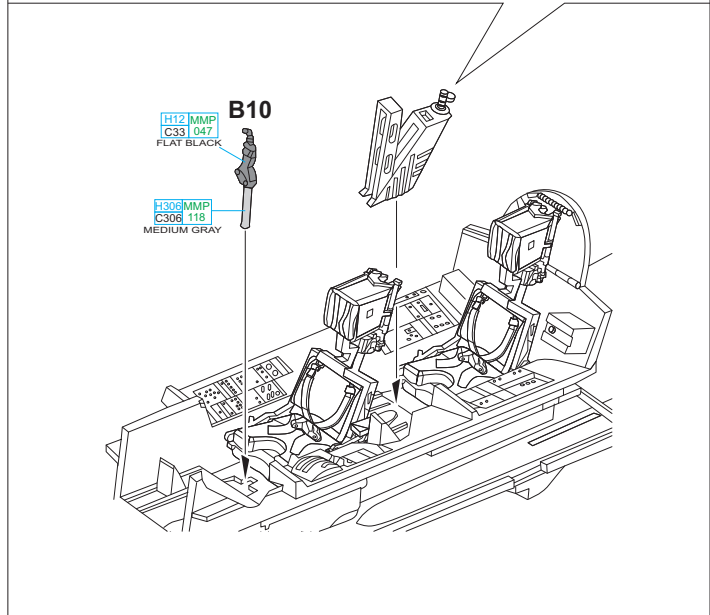
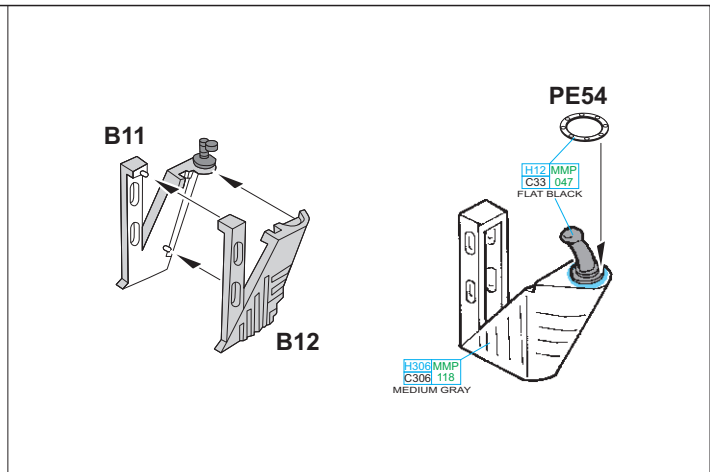
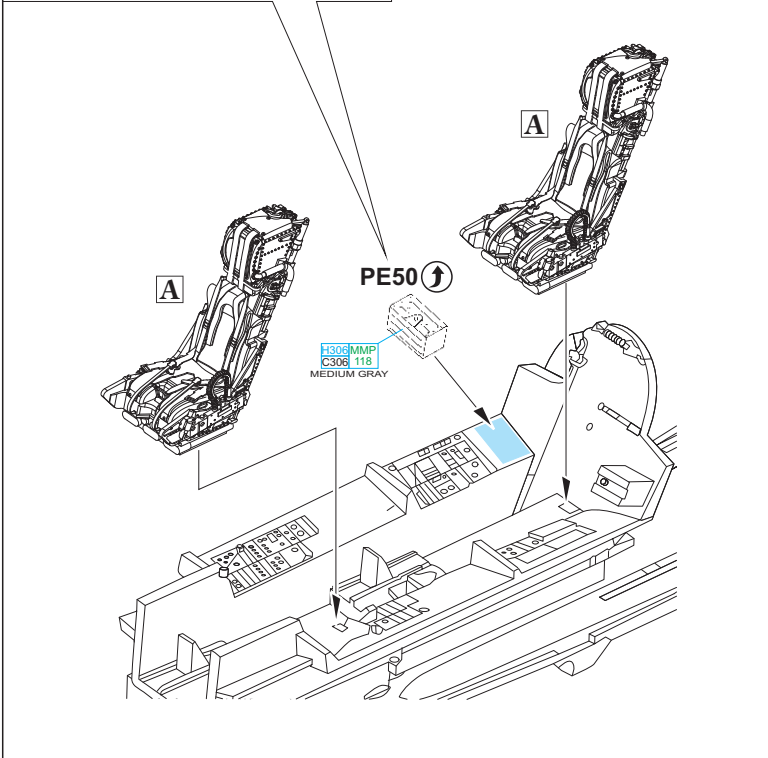
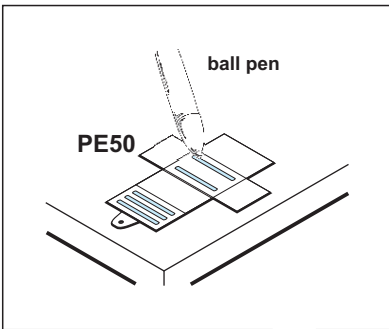

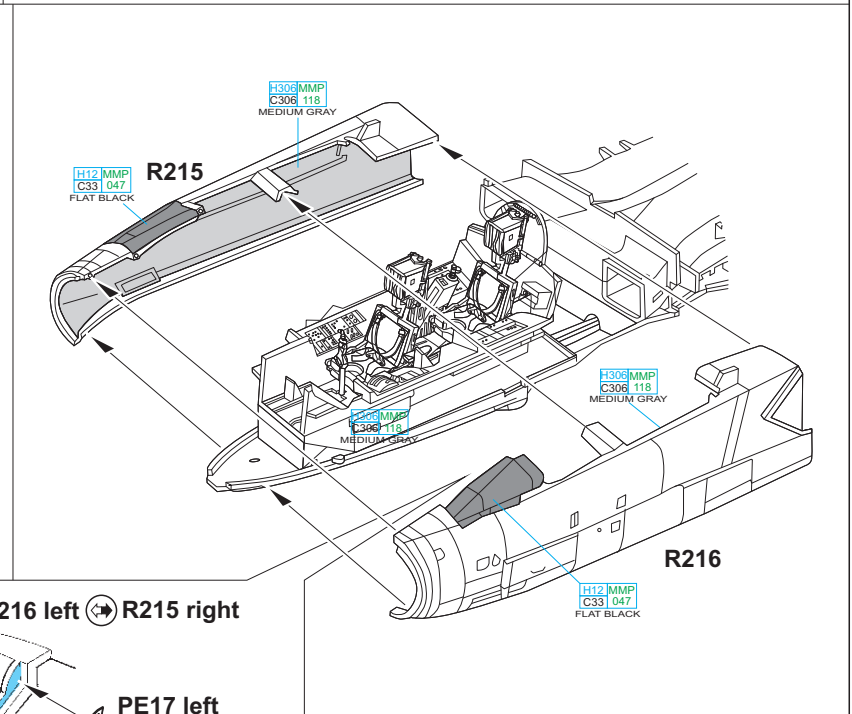
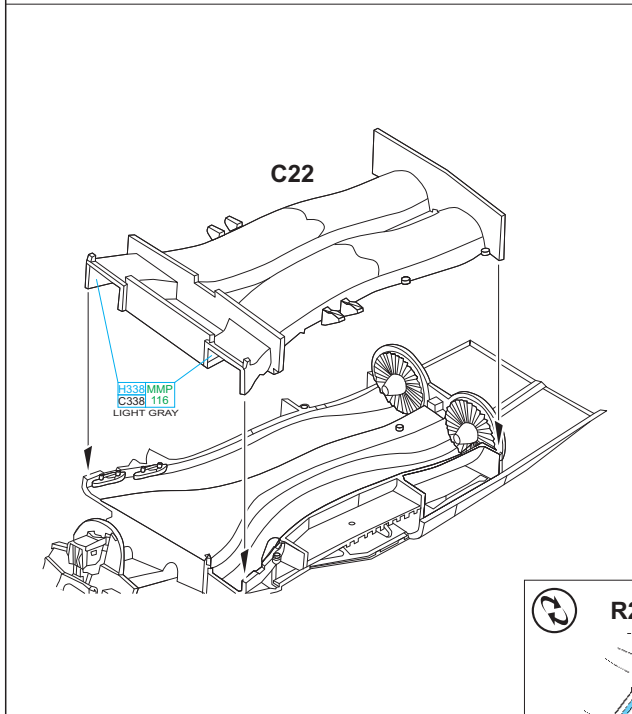
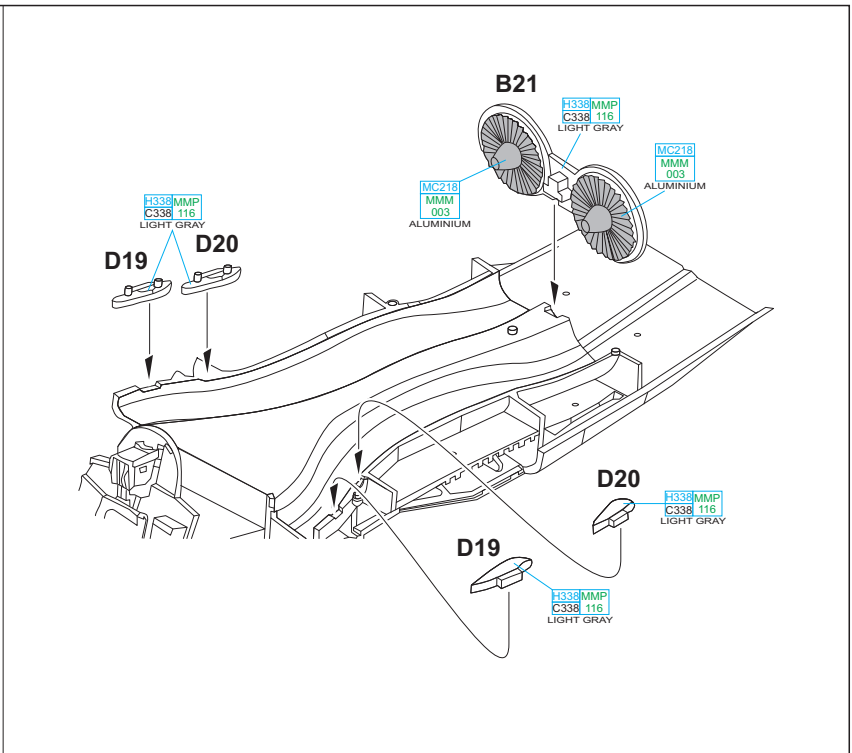
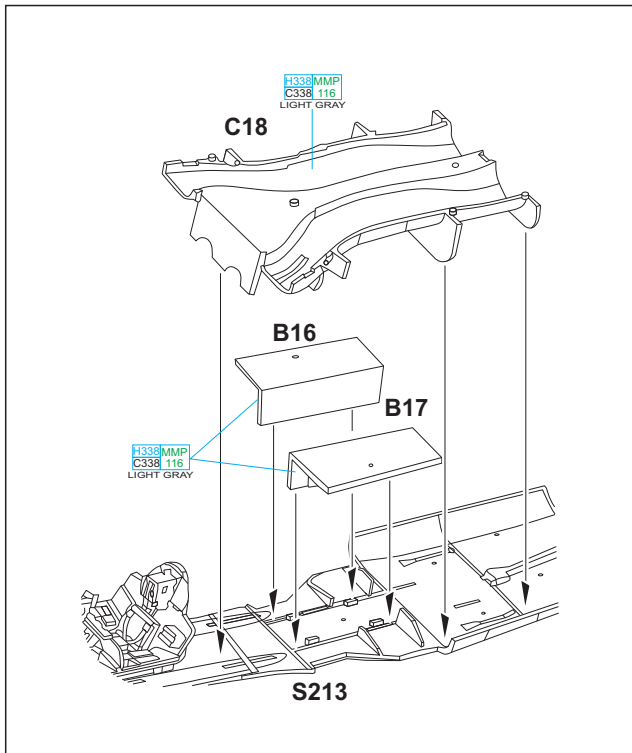

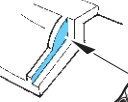

 R216 left ↔ R215 right
 PE17 left
 PE18 right
 OPTIONAL: decal 72 ↔ decal 73

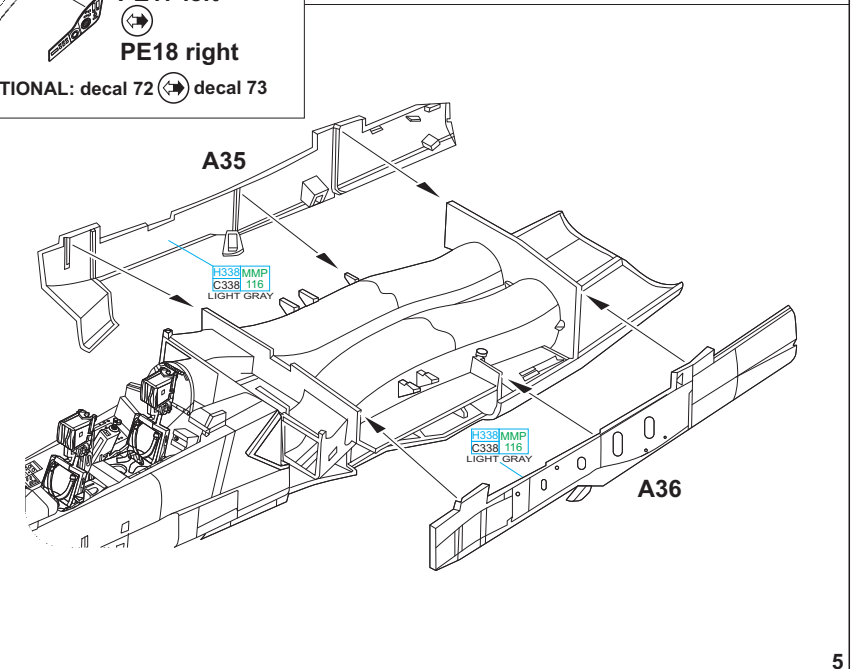
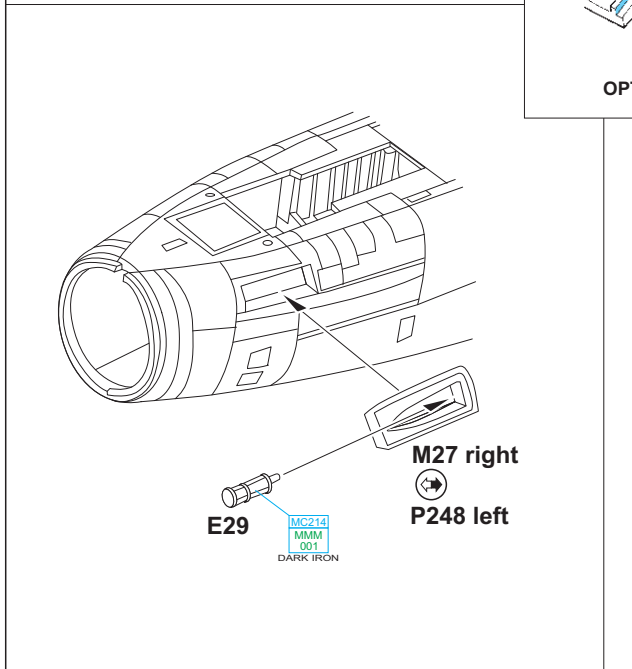

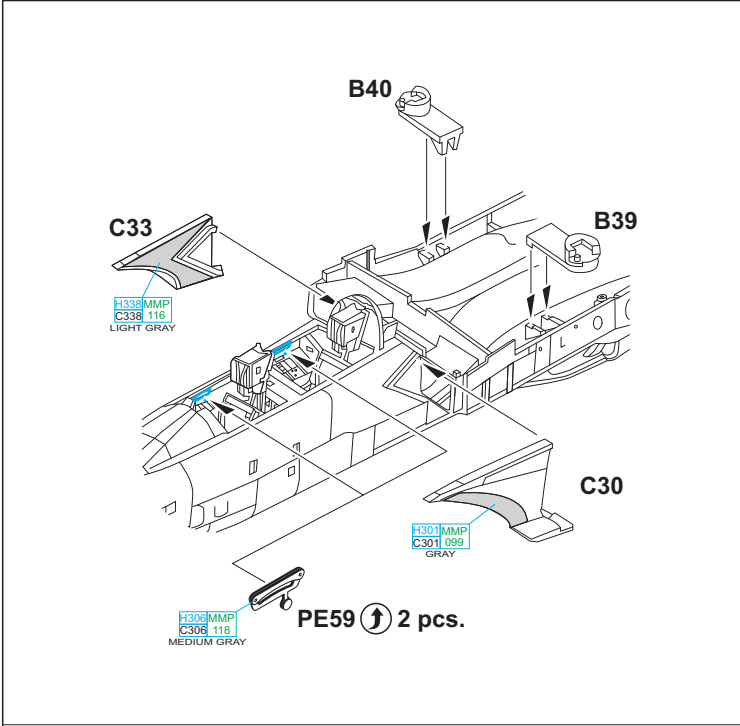

Flaps up

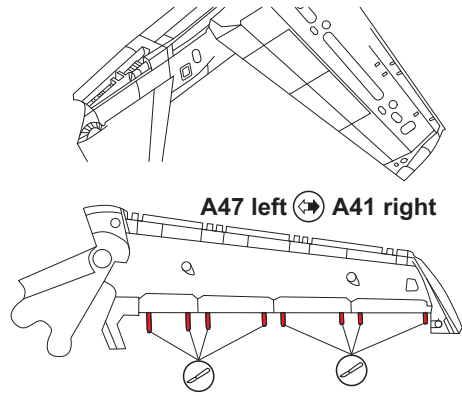

Flaps down

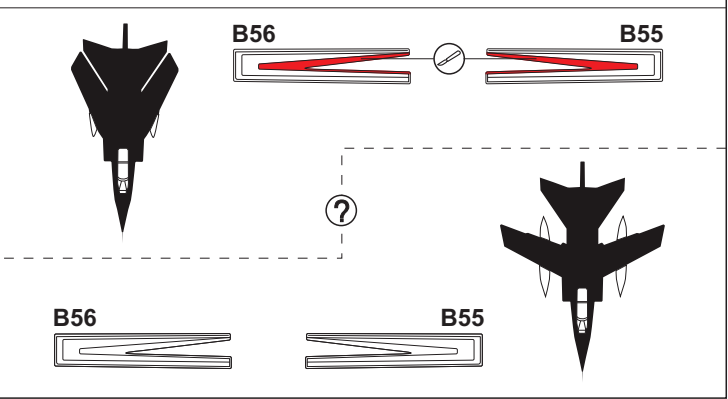
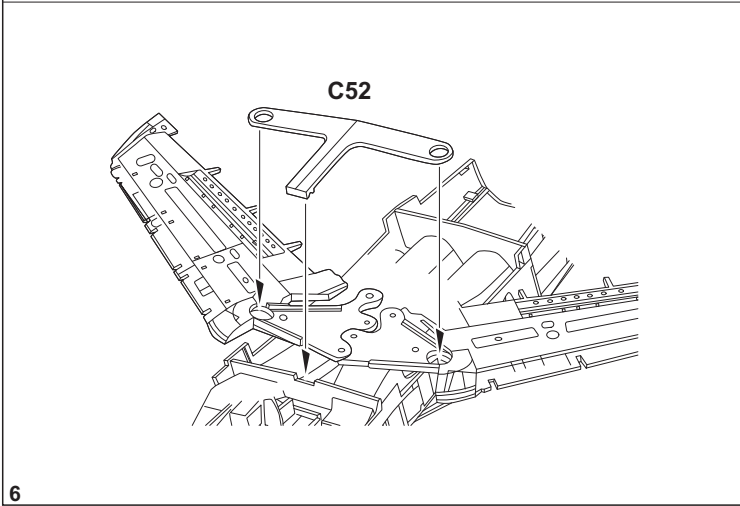
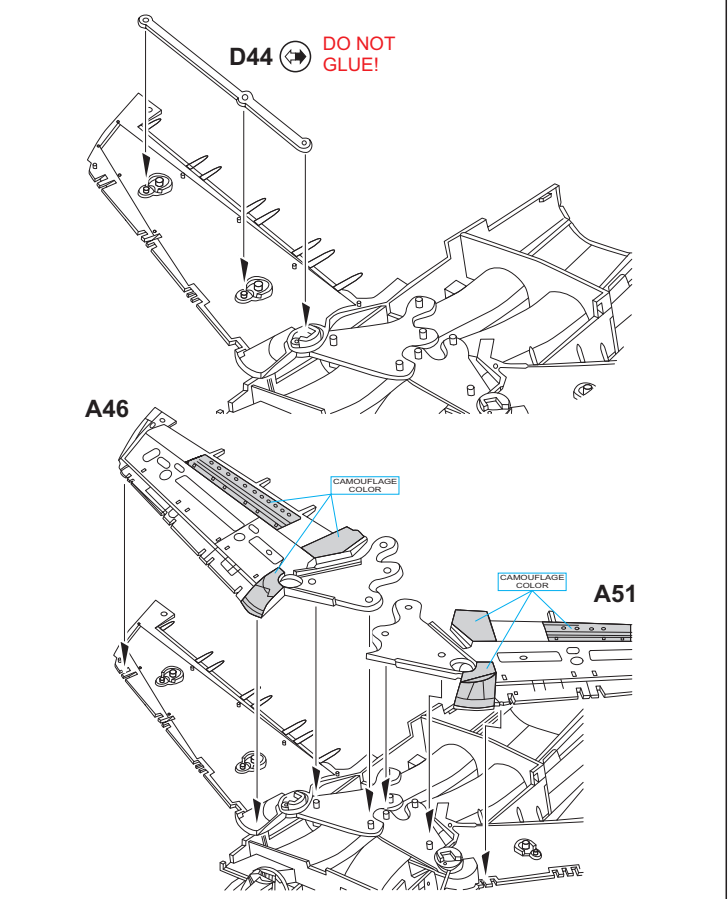
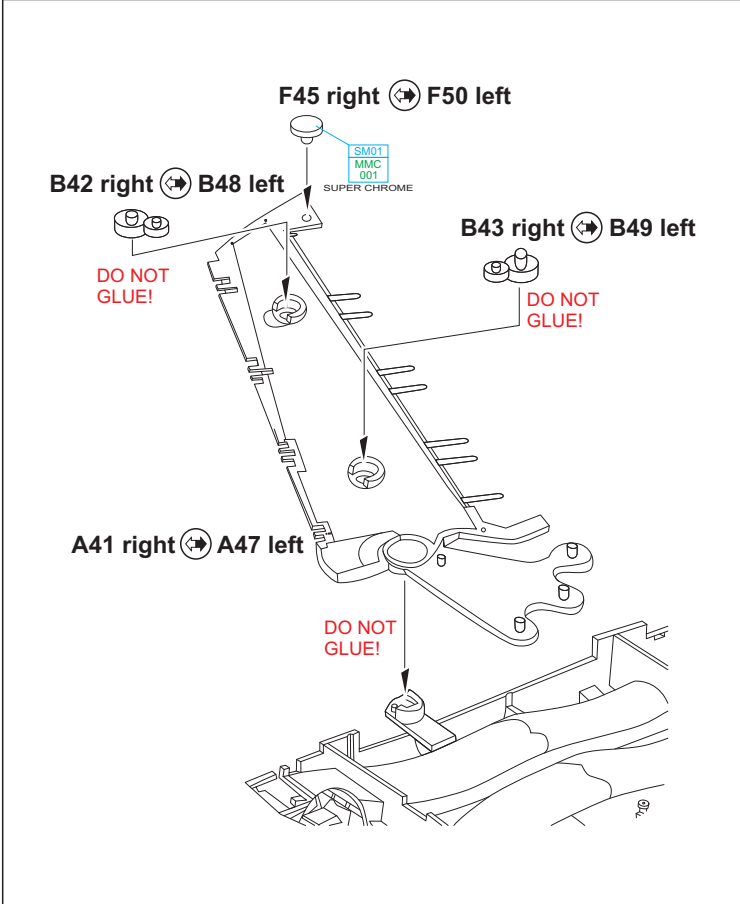
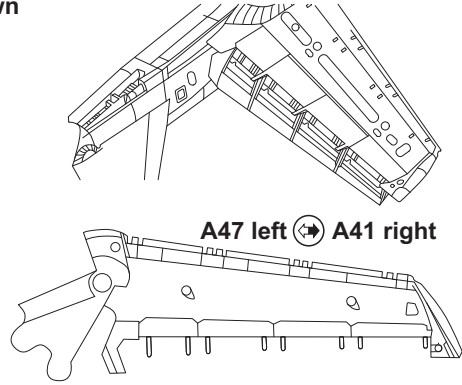

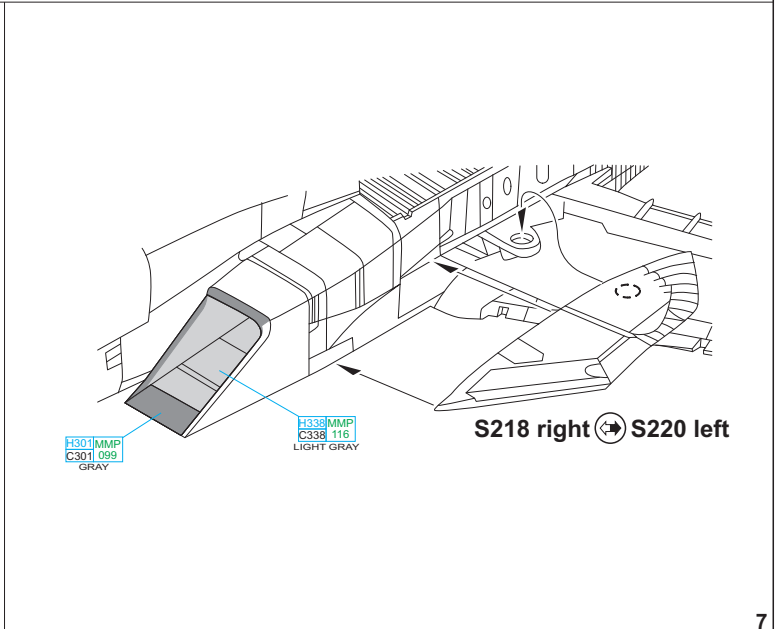
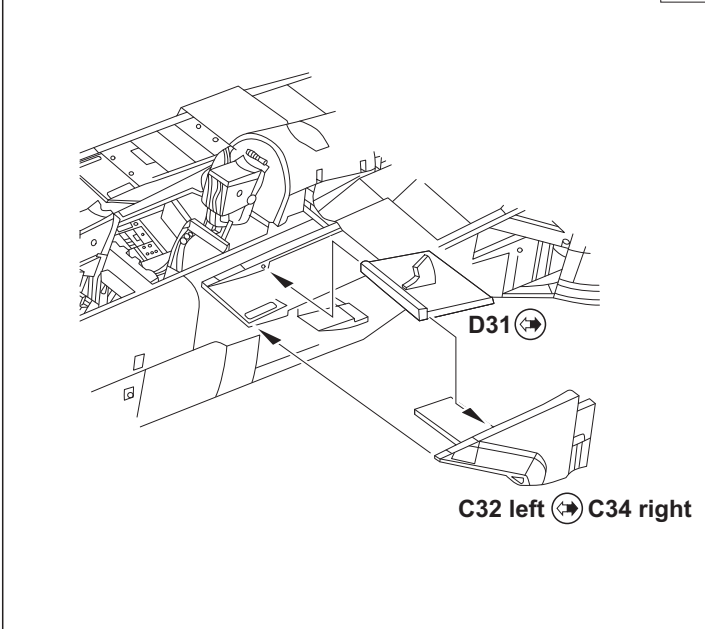
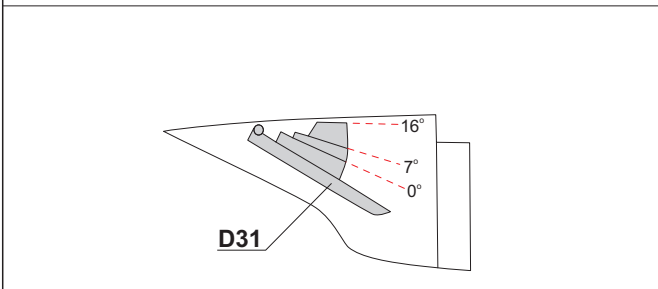
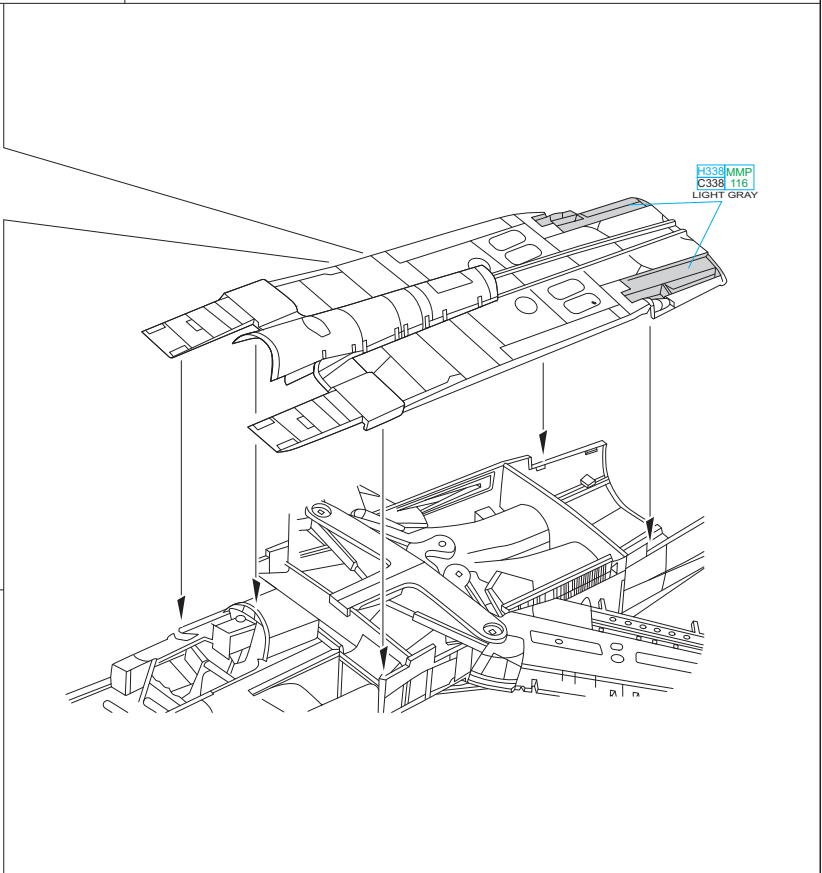
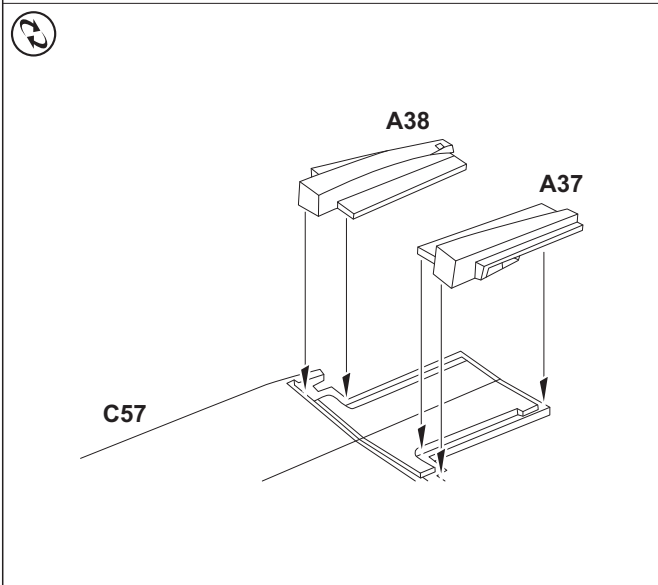
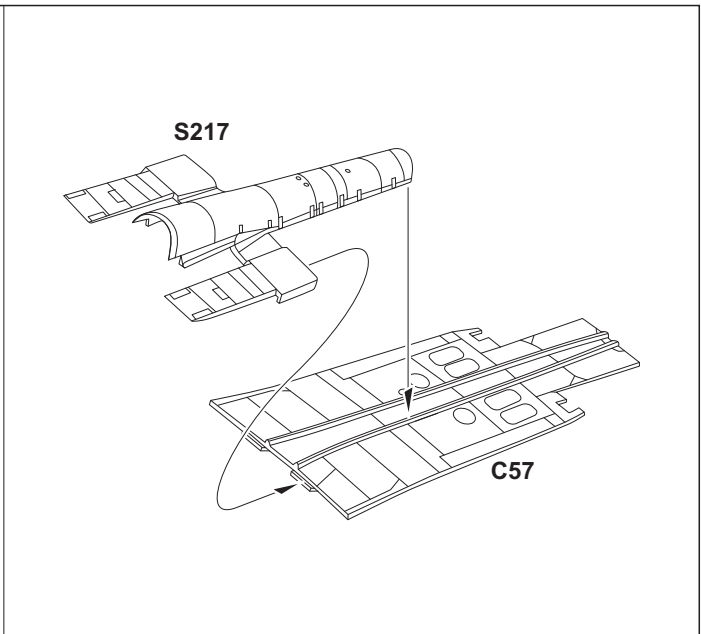
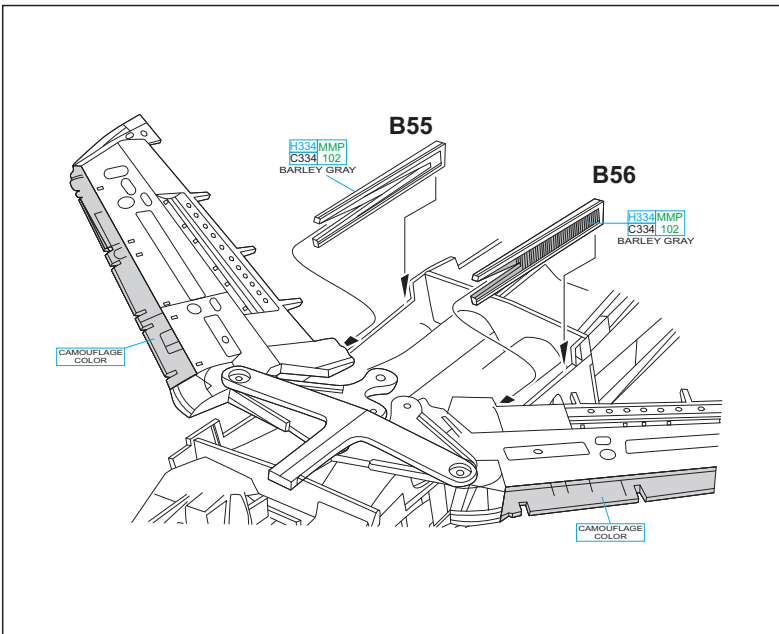

S221 left ↔ S219 right

DO NOT
GLUE!

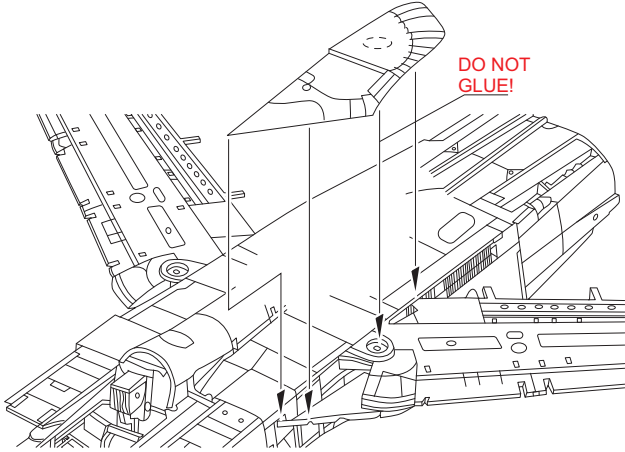

R223

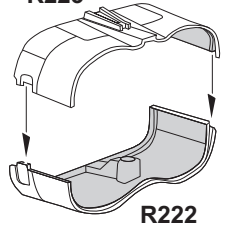

R222

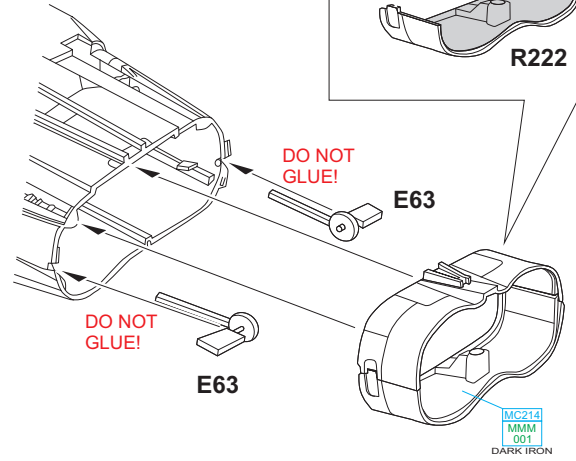

DO NOT
GLUE!

E63

E63

MC214
MMM
001
DARK IRON

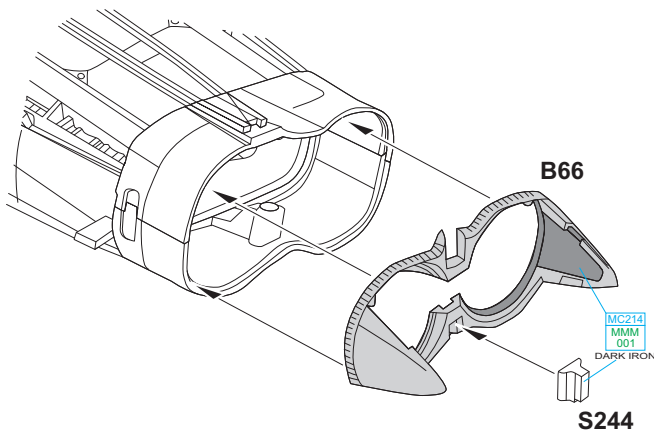

B66

S244

MC214
MMM
001
DARK IRON

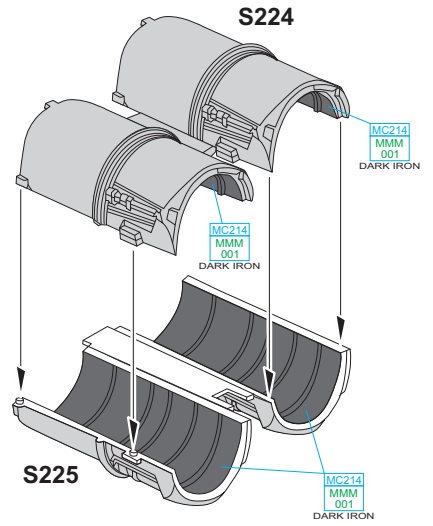

S224

S225

MC214
MMM
001
DARK IRON

MC214
MMM
001
DARK IRON

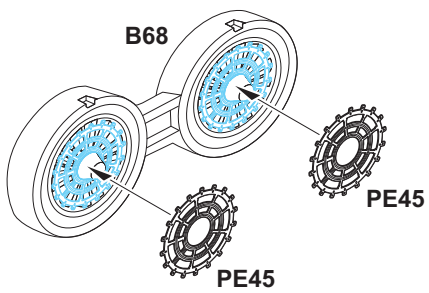

B68

PE45

PE45

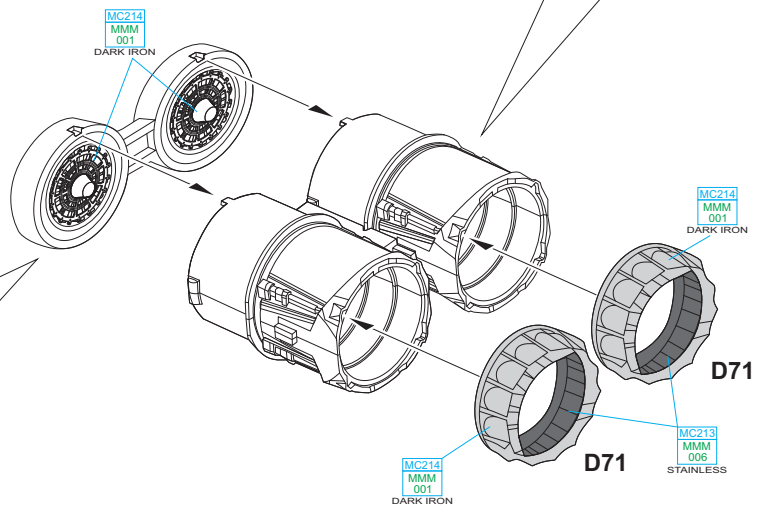

MC214
MMM
001
DARK IRON

MC214
MMM
001
DARK IRON

D71

D71

MC214
MMM
001
DARK IRON

MC213
MMM
005
STAINLESS

E

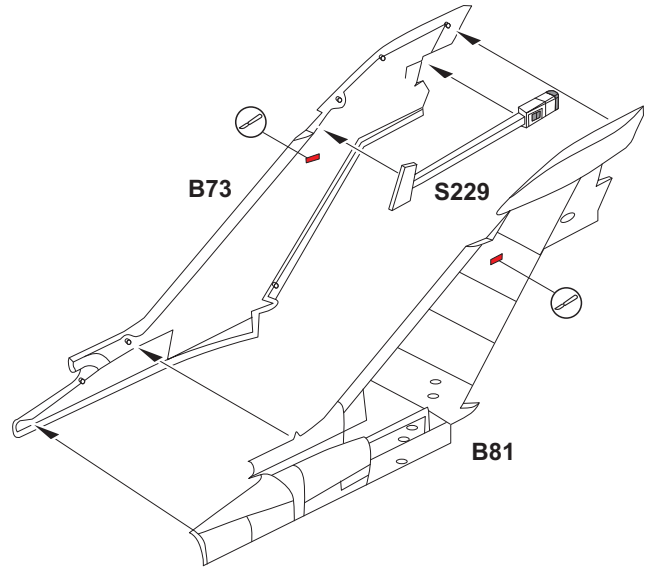
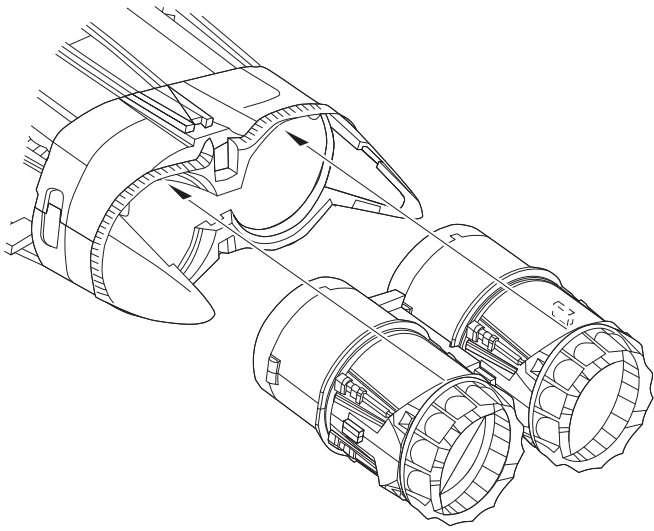

F

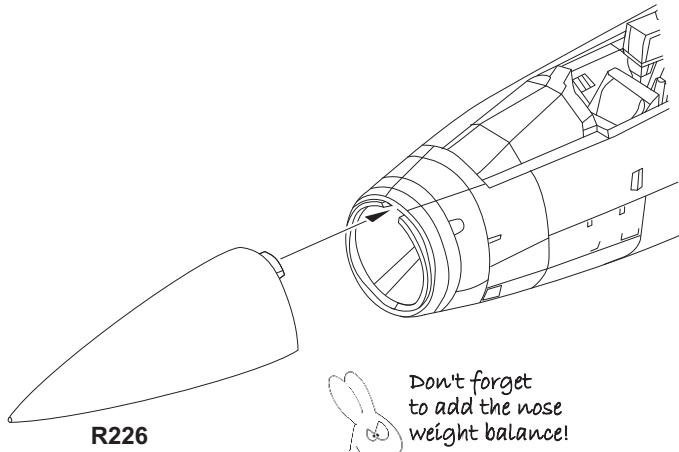
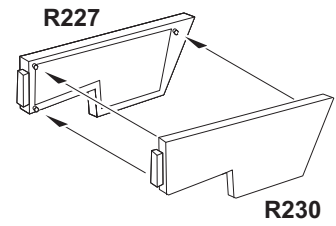

R226



Don't forget to add the nose weight balance!

R230

G

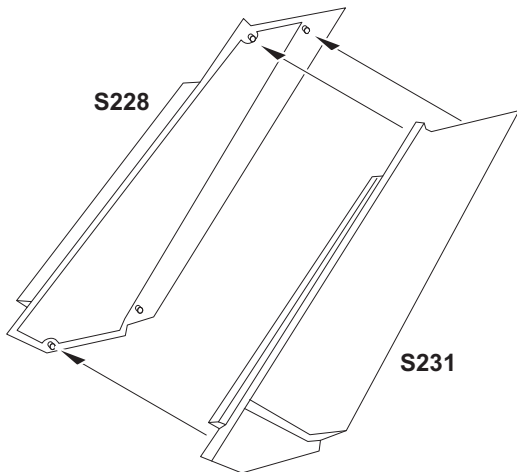

S228

S231

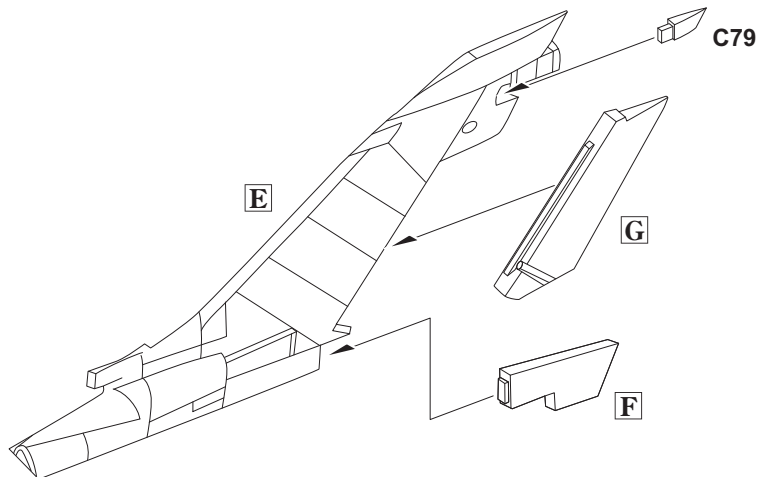

E

G

F

C79

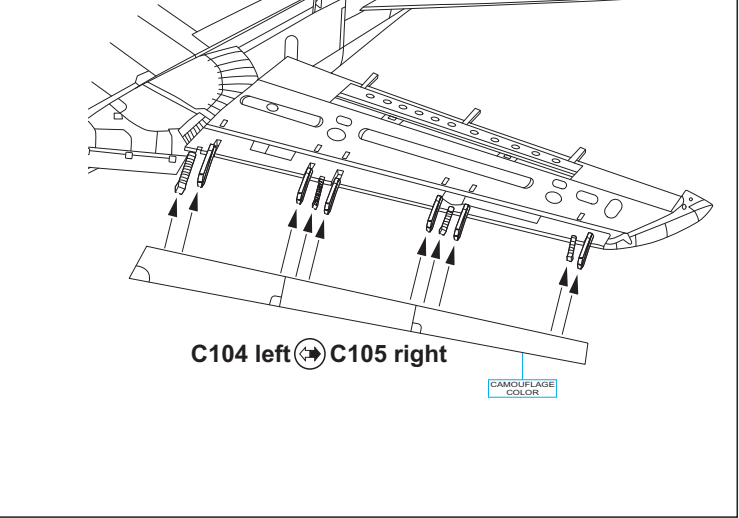
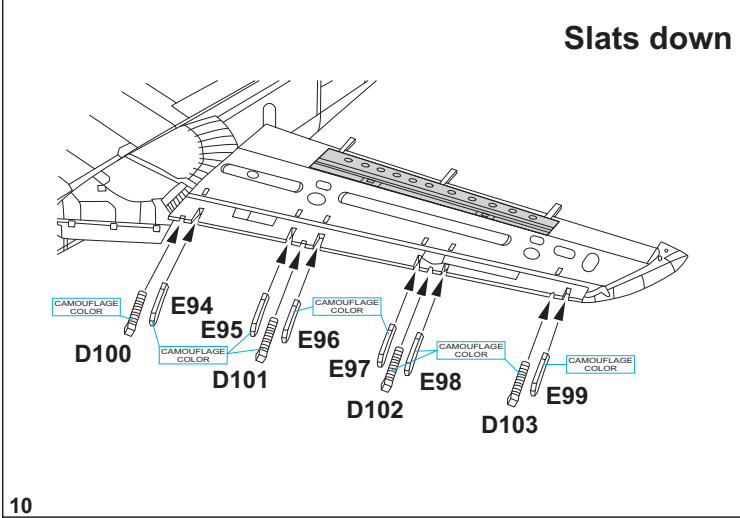
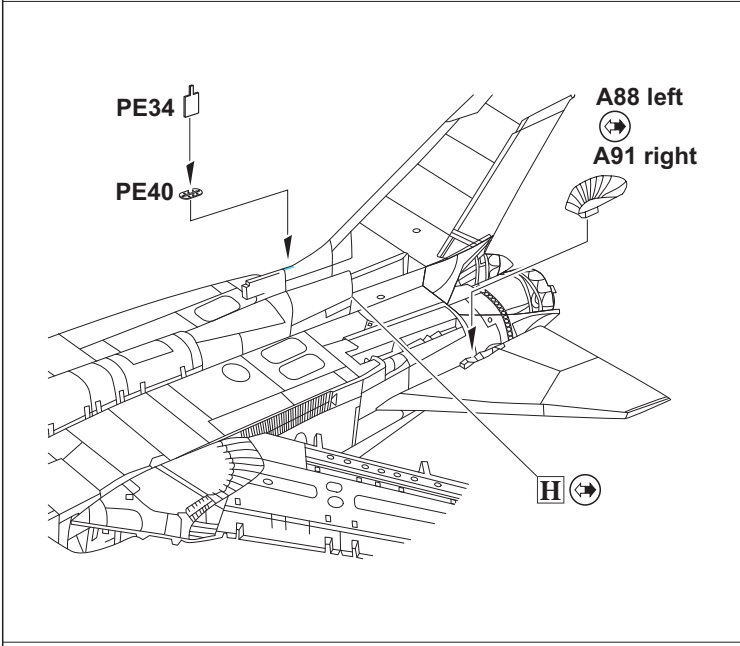
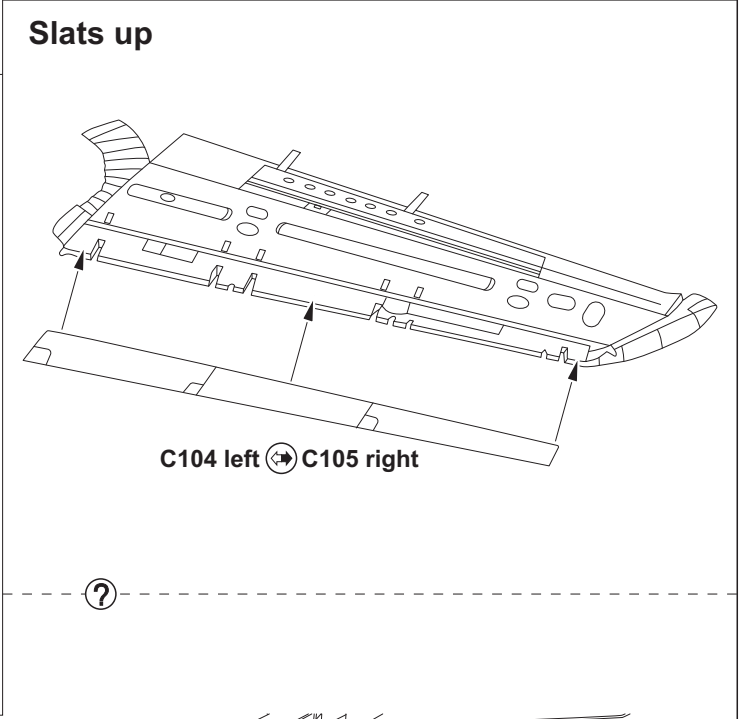
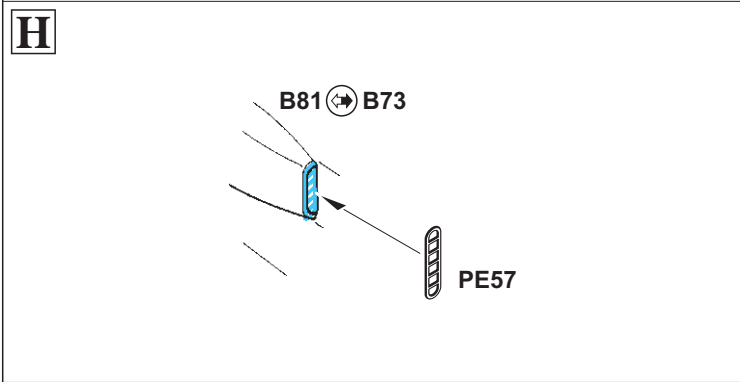
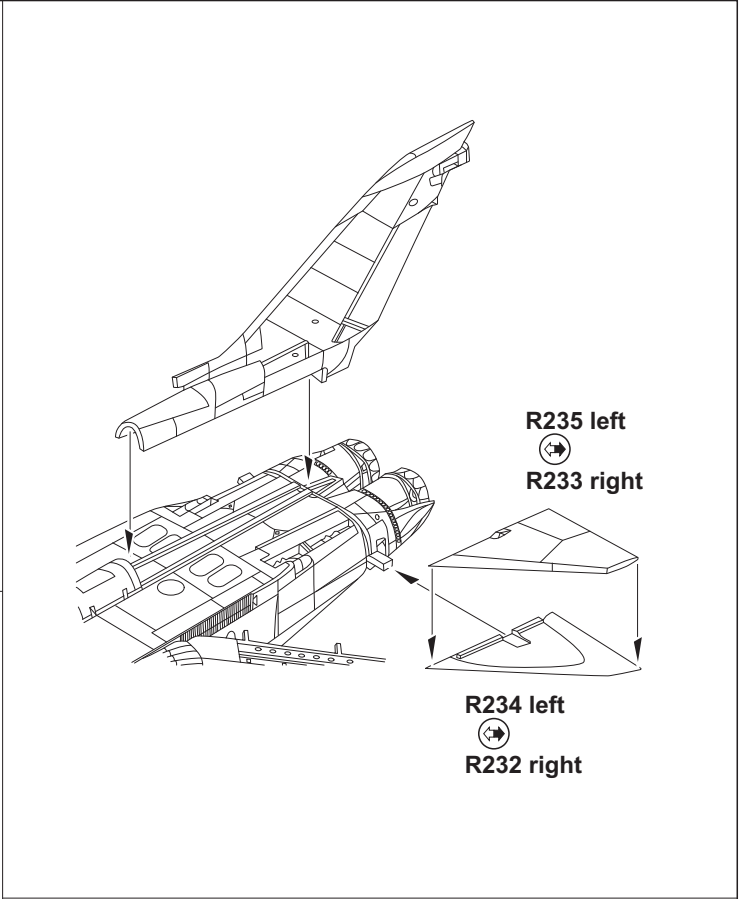
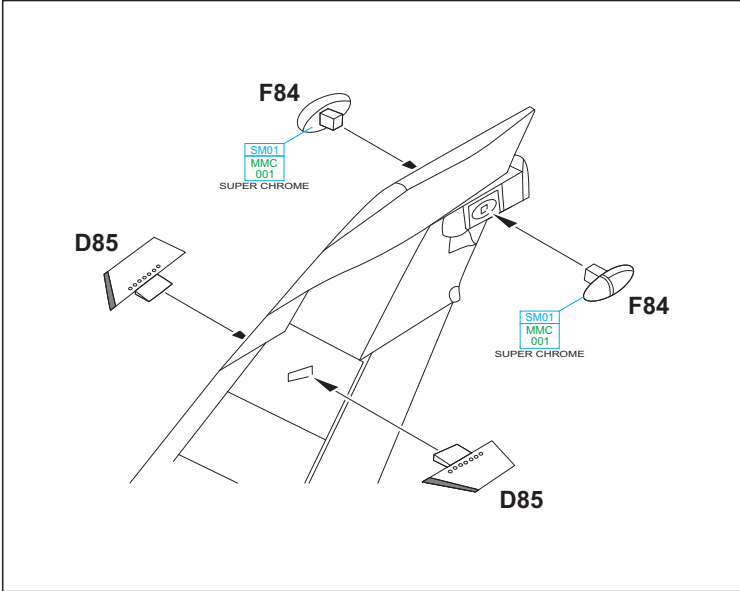

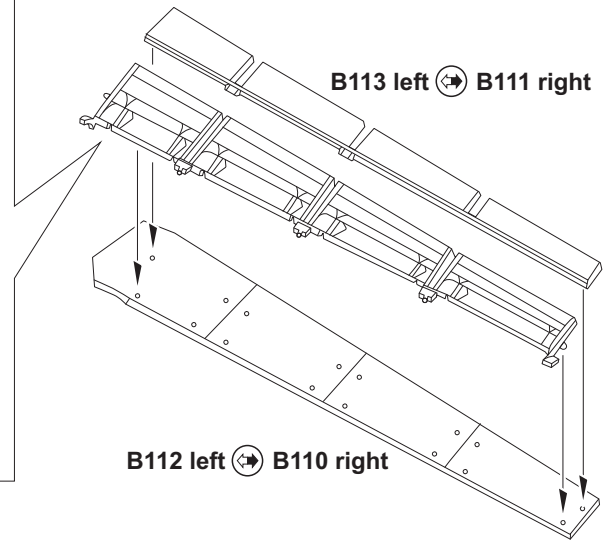
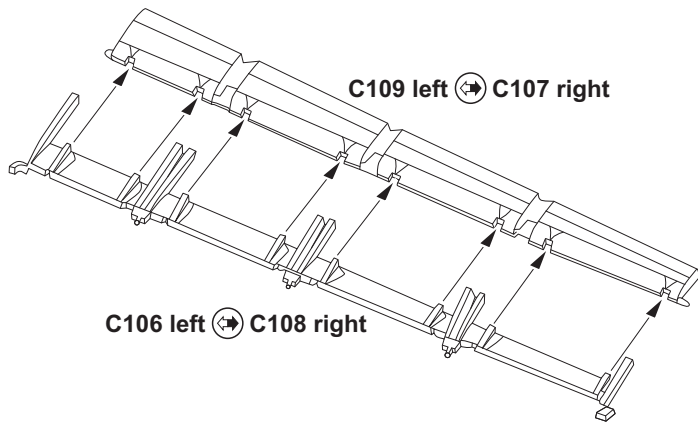

Flaps down

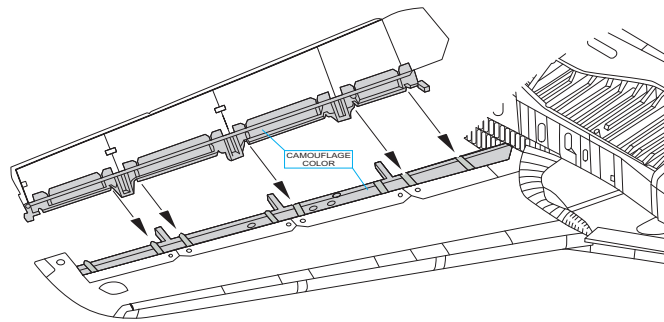

?

Flaps up

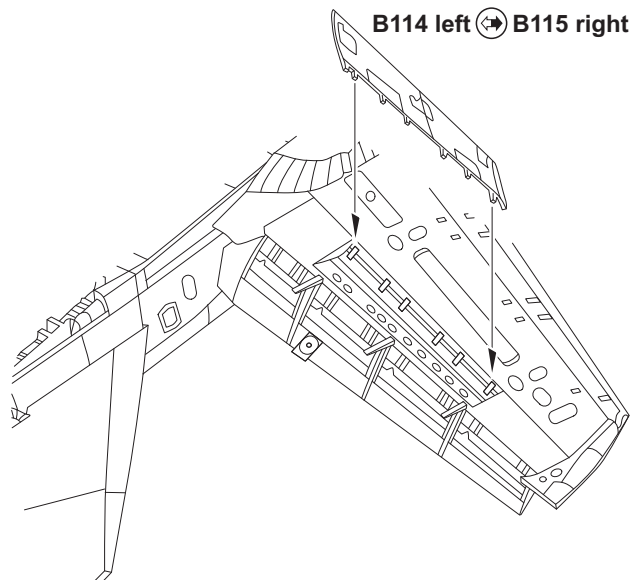
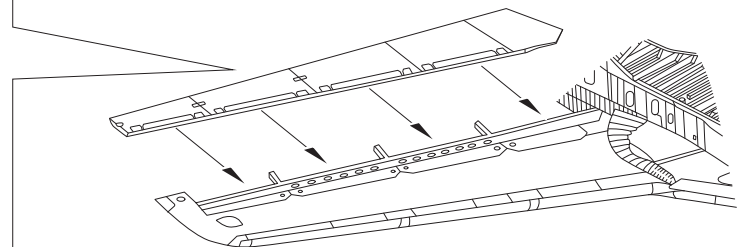
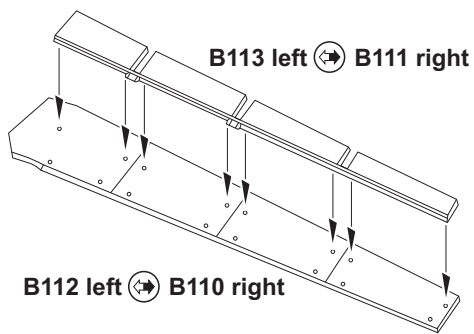

?

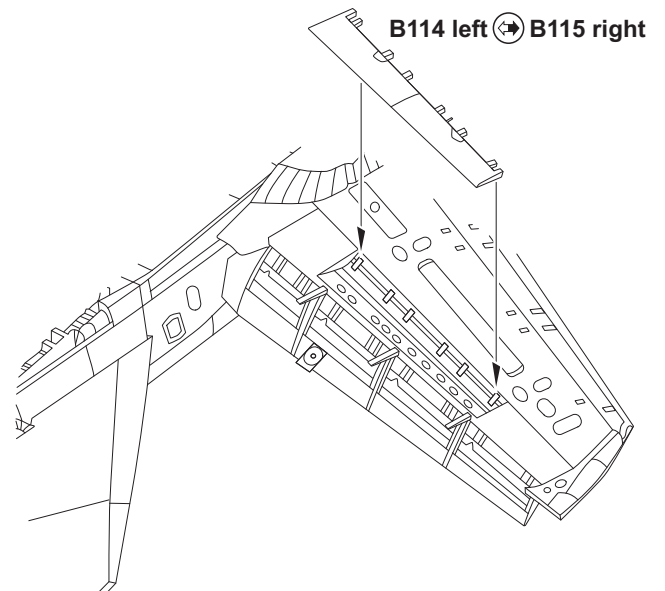

J

B119 right



B116 left

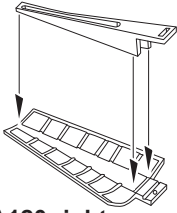

A120 right



A118 left

D117

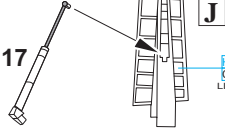

J

F338MMP
C338 116
LIGHT GRAY

SM01
MMC
001
SUPER CHROME

D117

F338MMP
C338 116
LIGHT GRAY

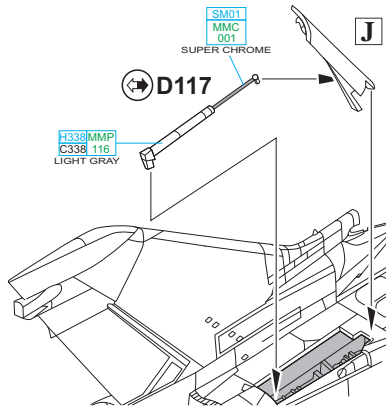

?

A120 right → **A118 left**

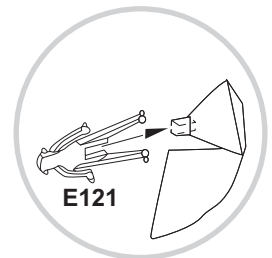
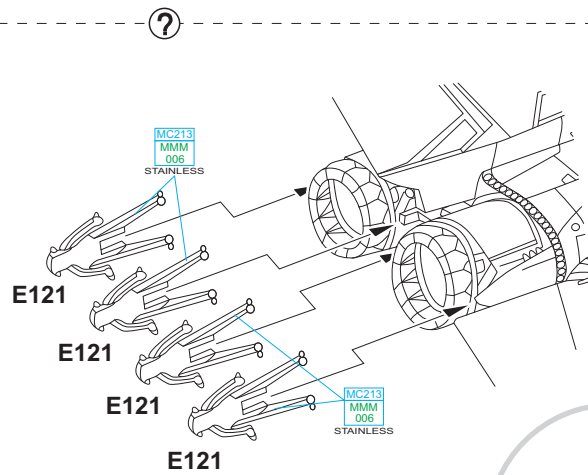
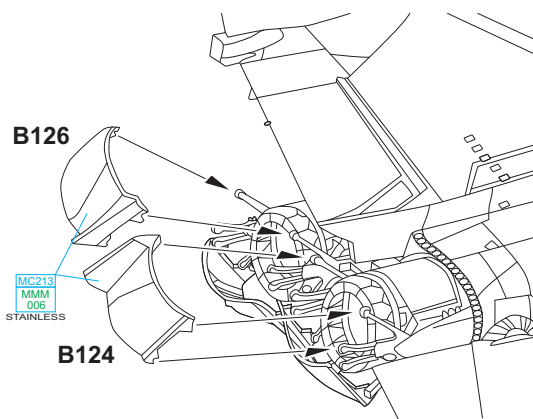
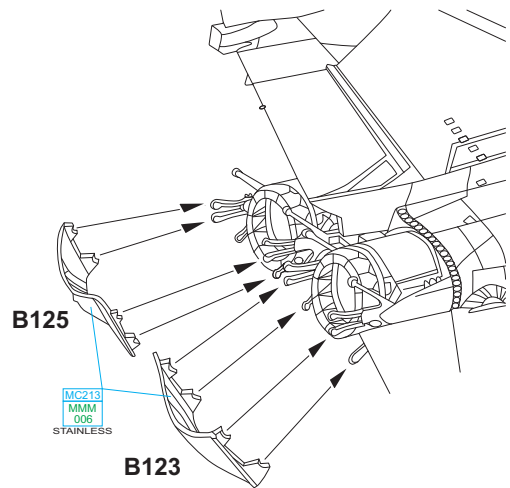
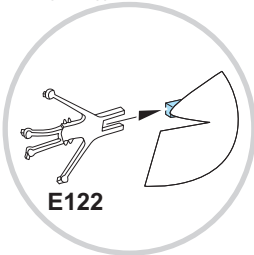
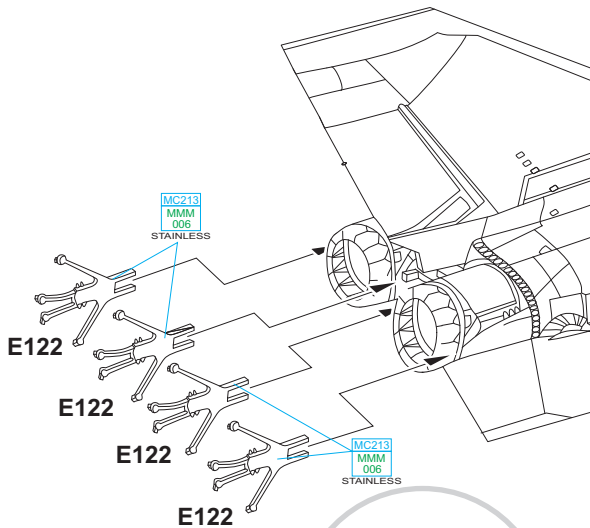
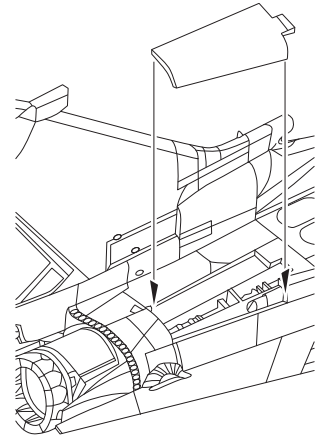

?

K

B124 right → B126 left

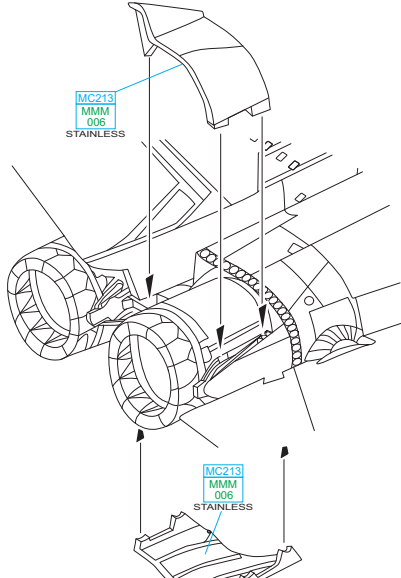

B123 right → B125 left

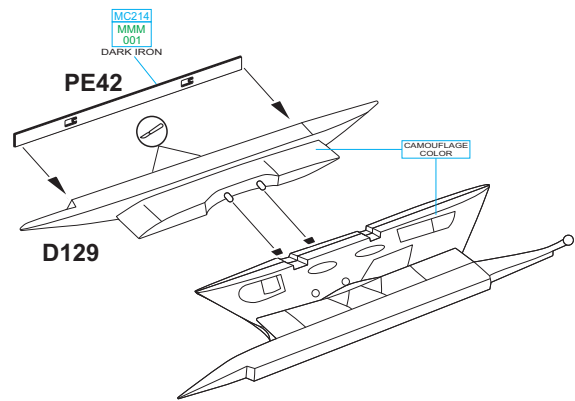
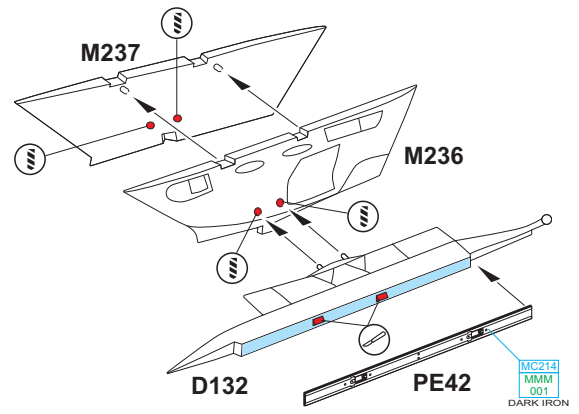
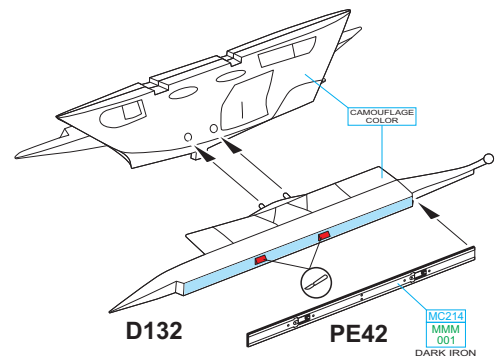
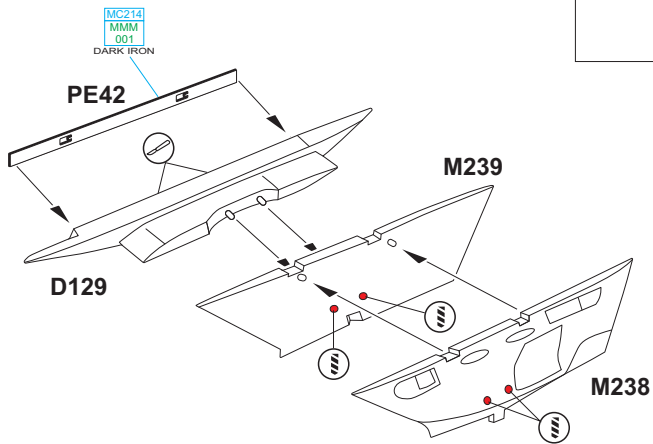
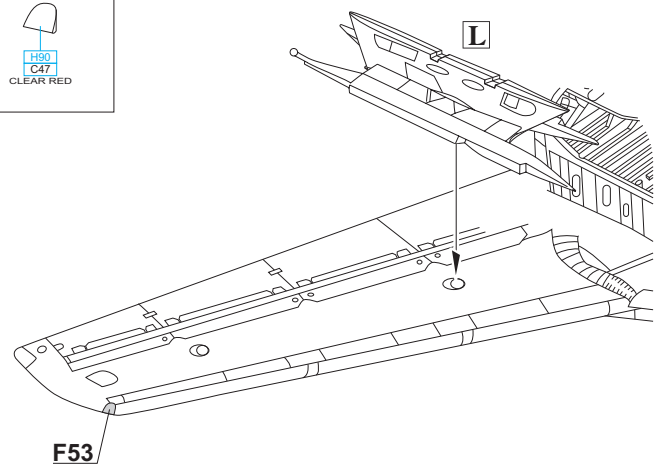
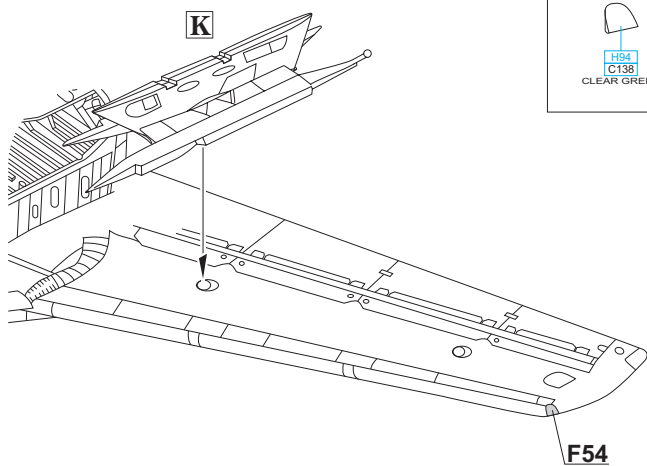
**L****F54**F54
C138
CLEAR GREEN**F53**F53
C47
CLEAR RED

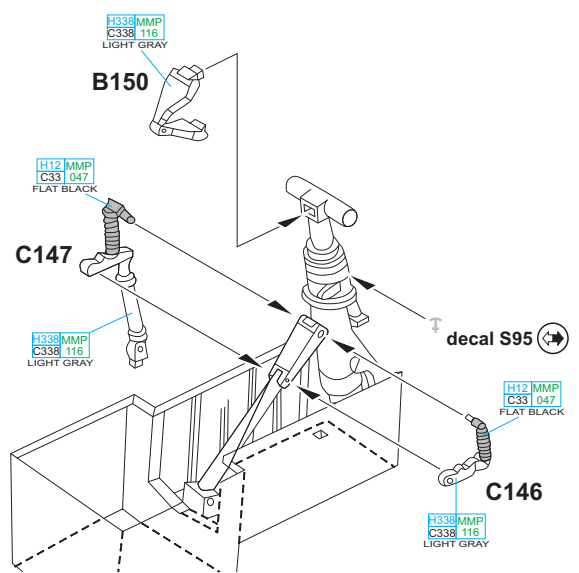
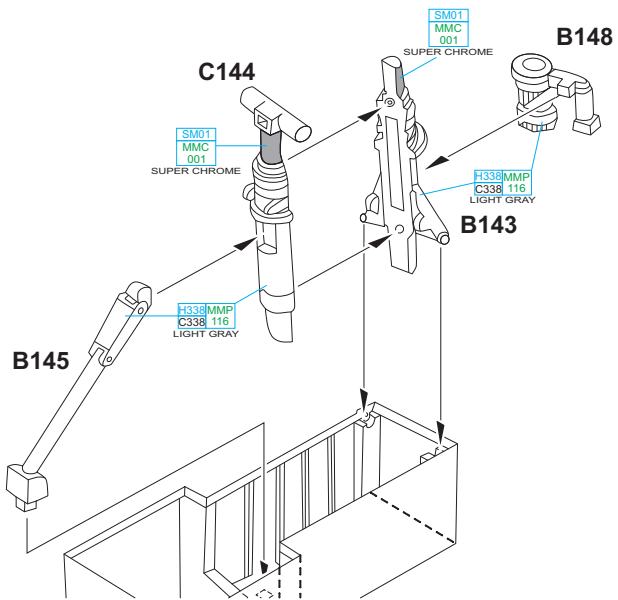

eduard
BRASSIN

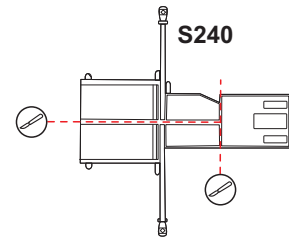
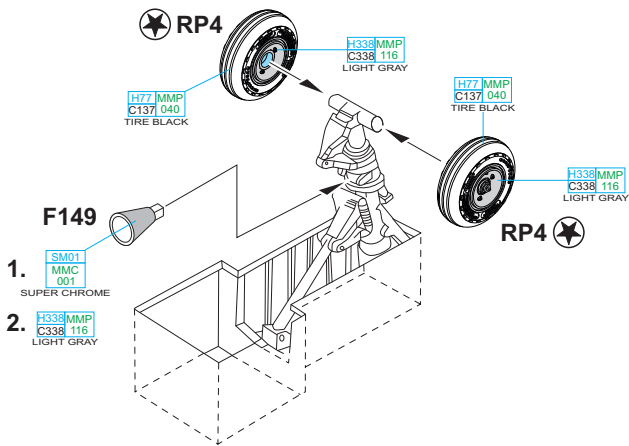

M **N**

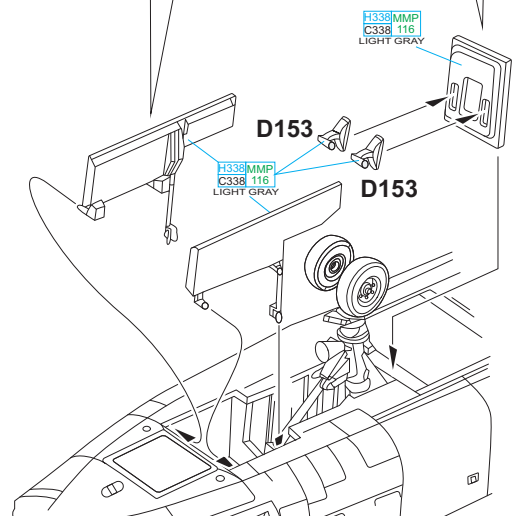
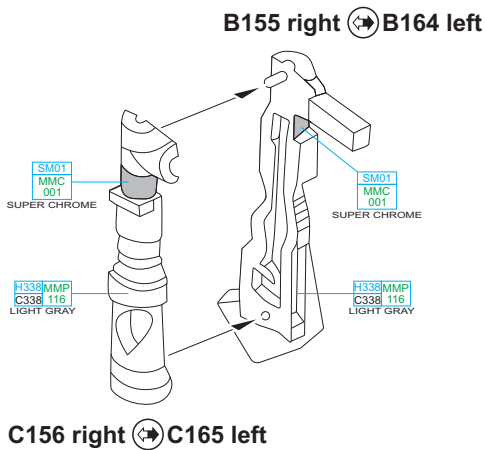

M N

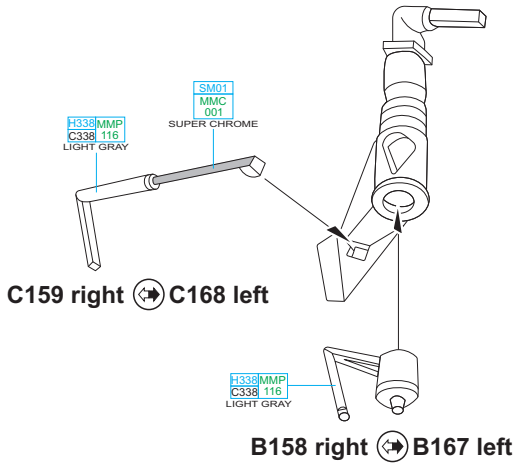

M N

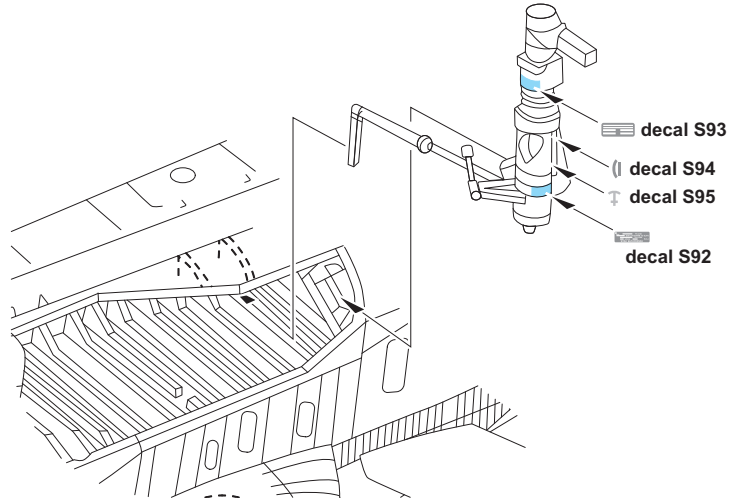

M N

B157 right ↔ B166 left

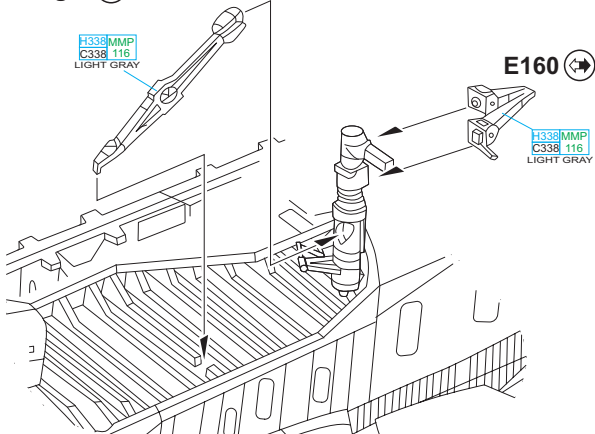

M N

eduard BRASSIN

RP1 ↔

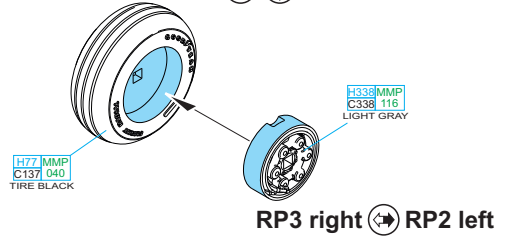

M N

M N

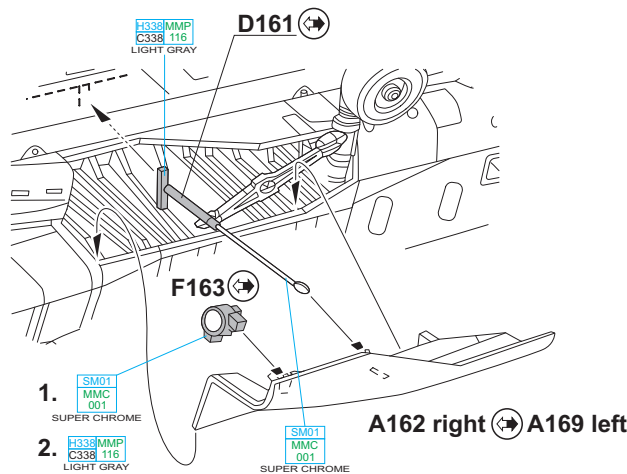

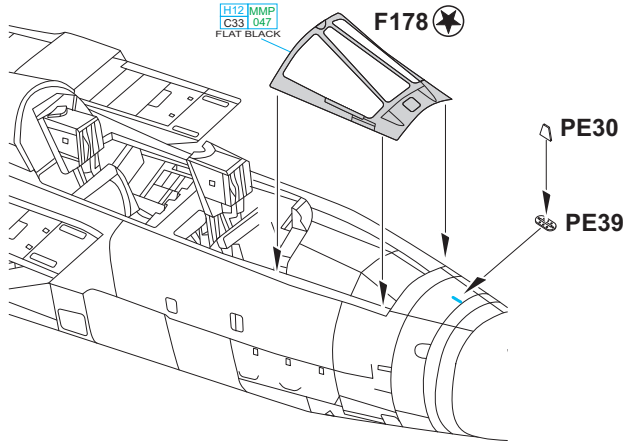

PE16 - MARKING B ONLY

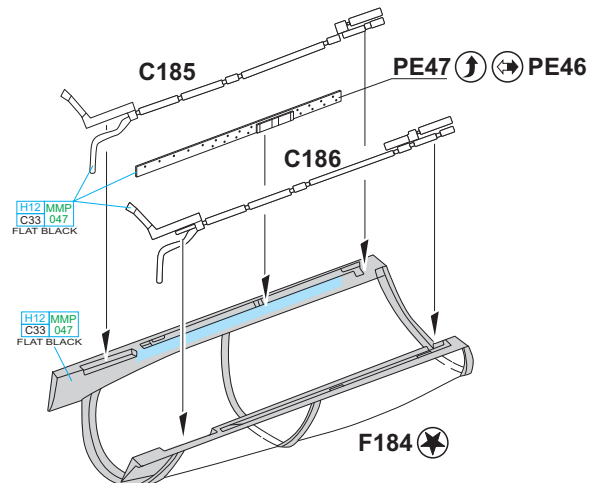
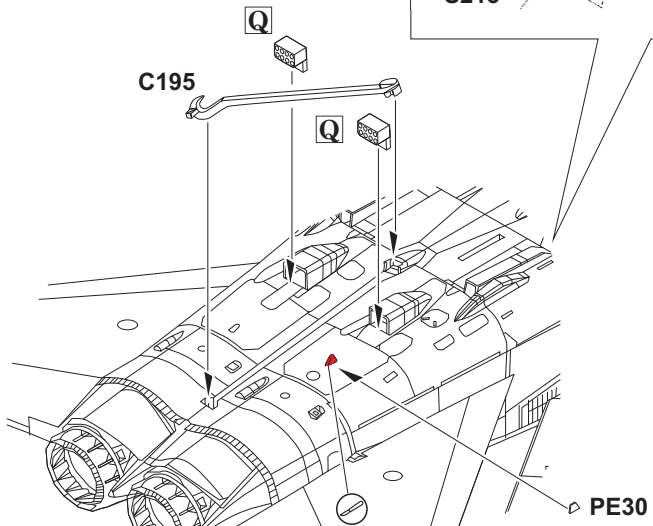
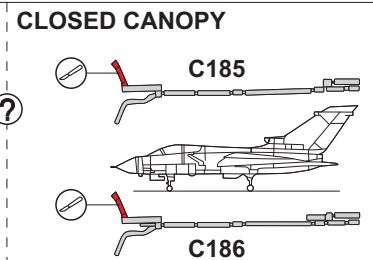
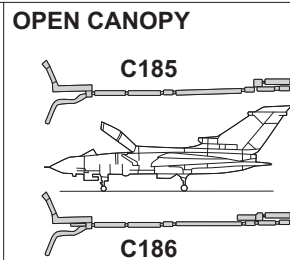
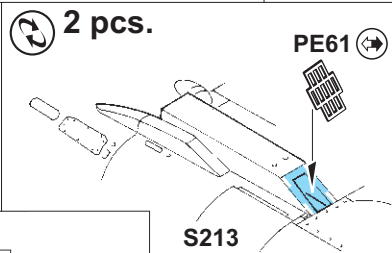
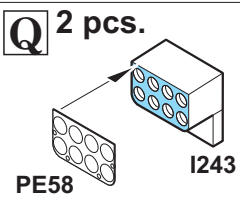
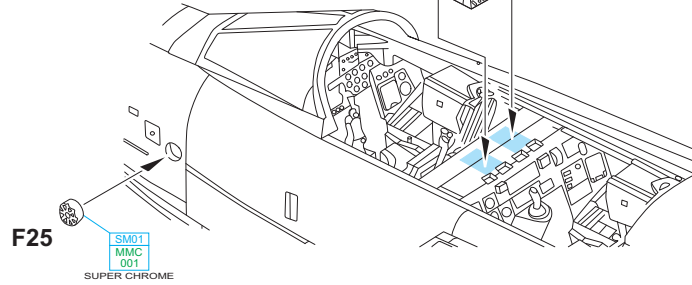
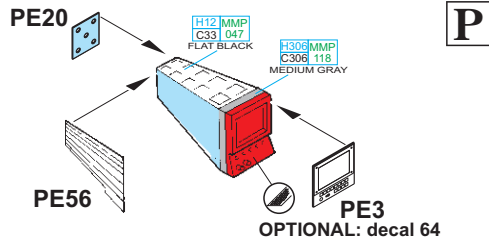
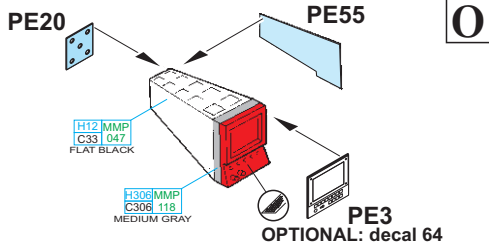
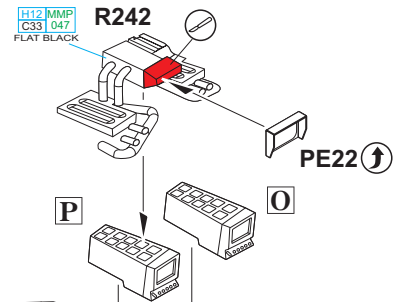
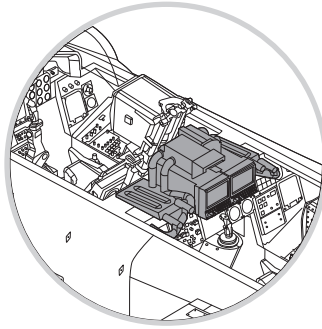
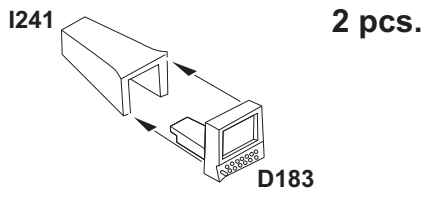
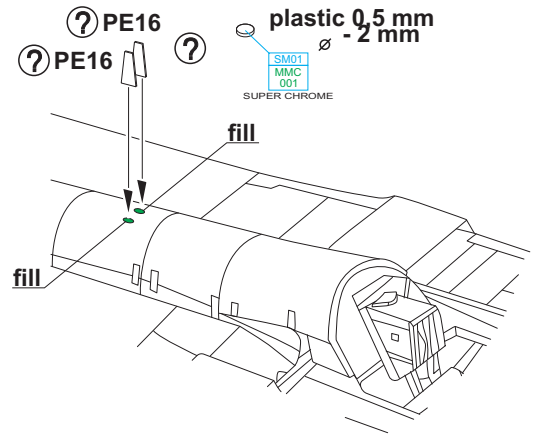

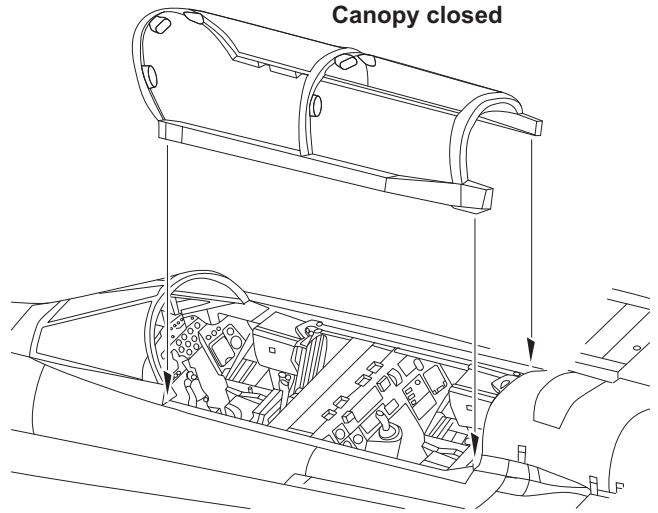
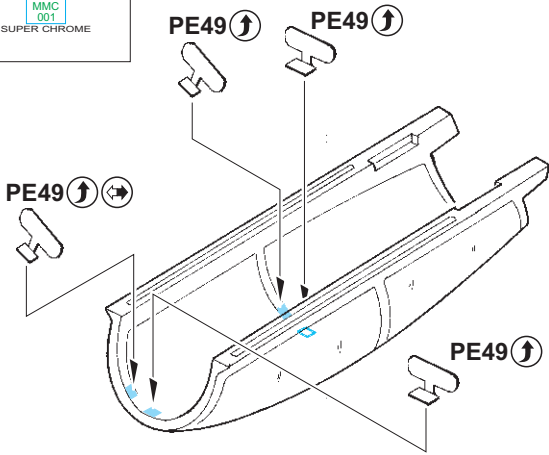
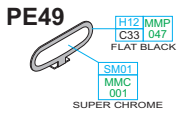

?

Canopy open

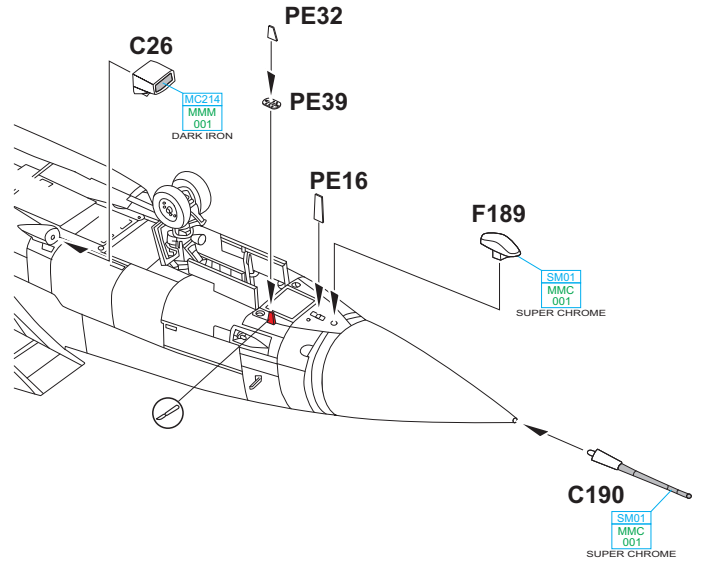
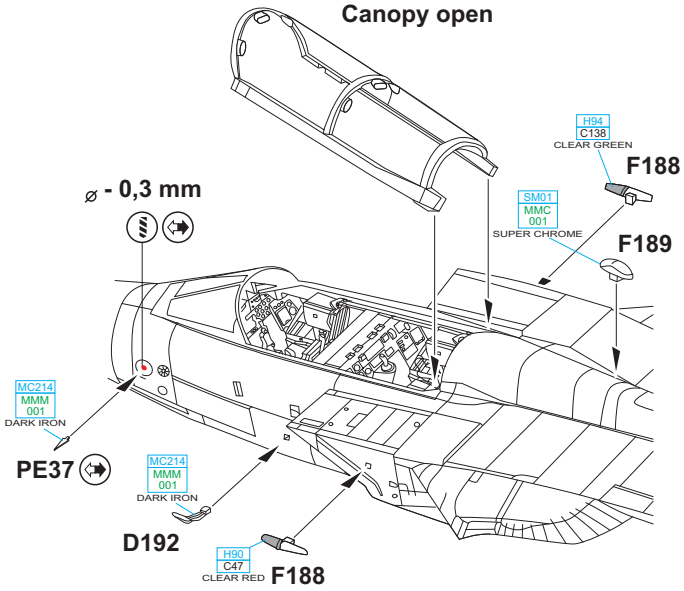

R 4 pcs.

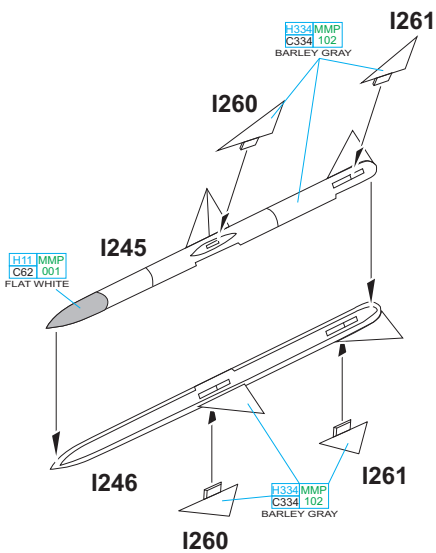

S 2 pcs.

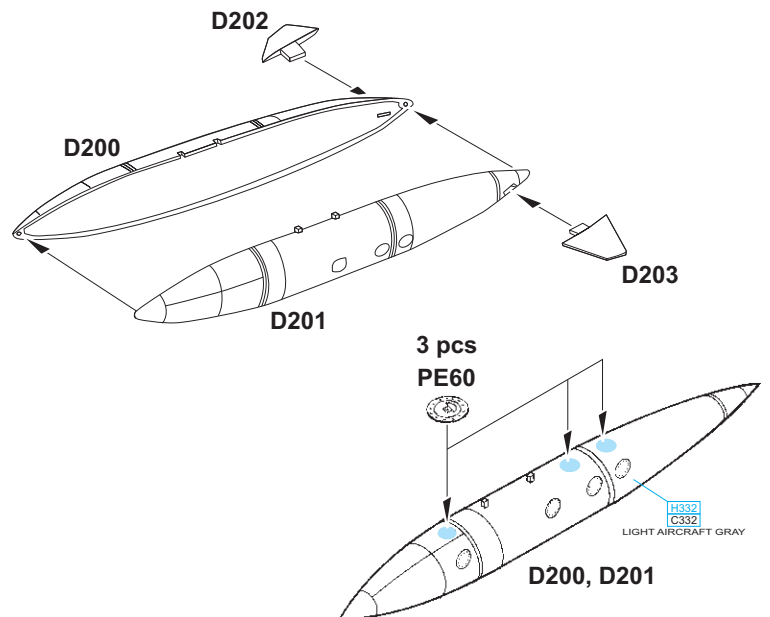

T 2 pcs.

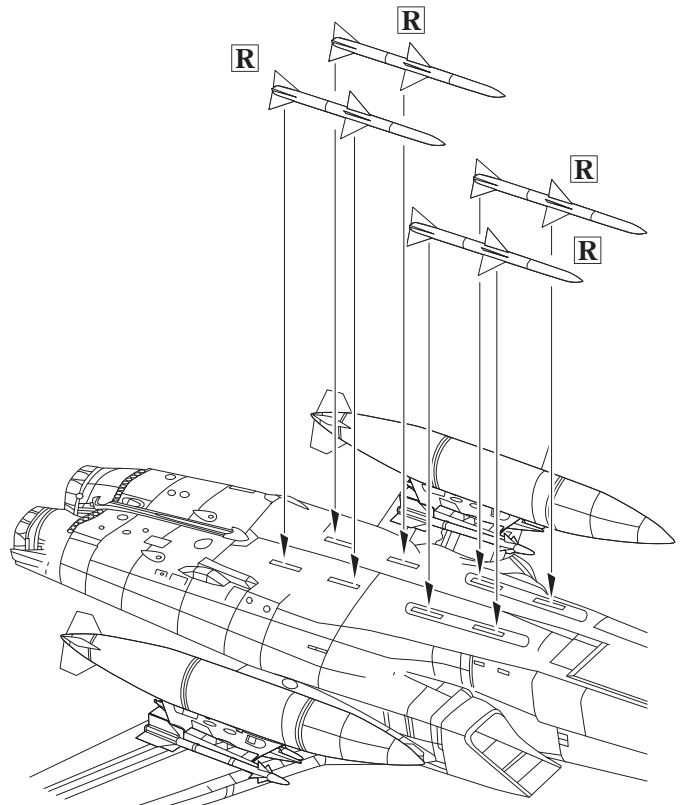
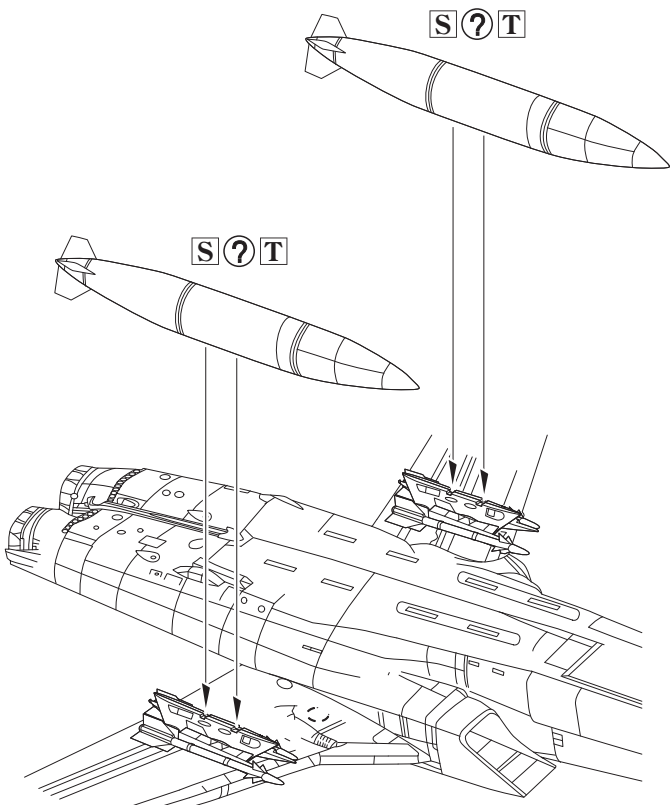
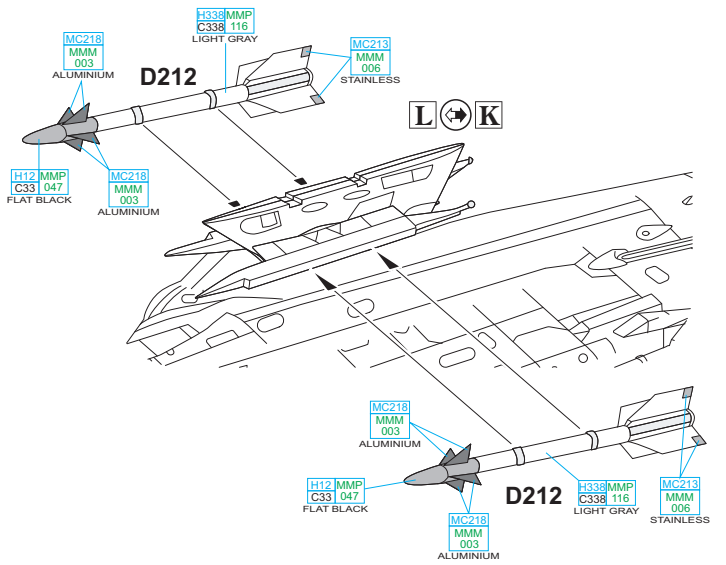
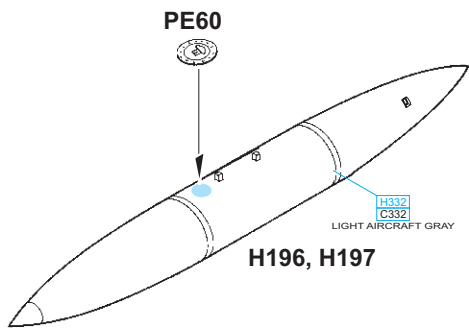
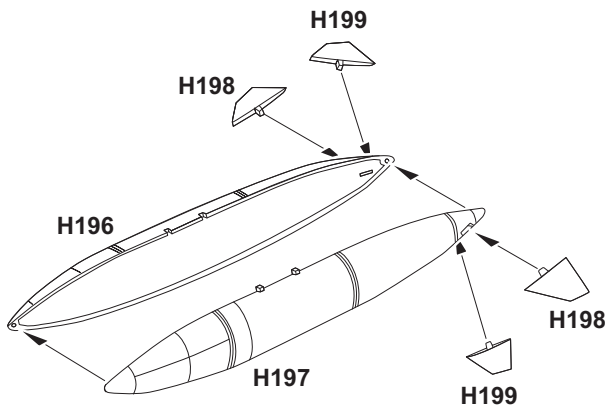

11126

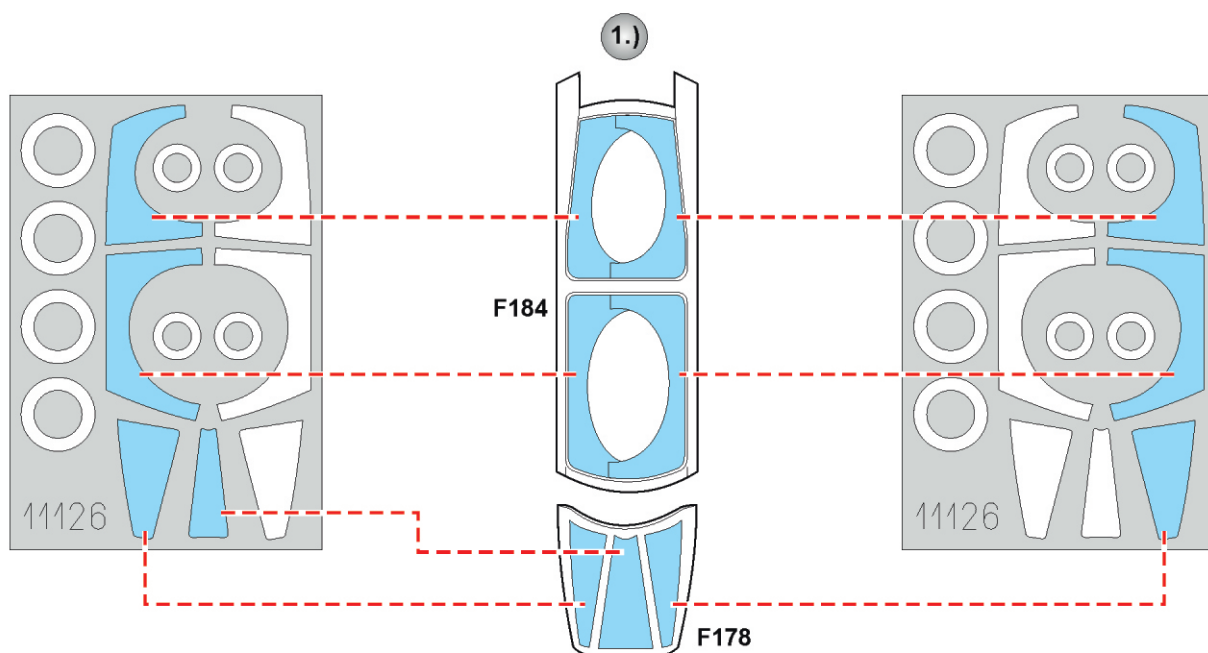
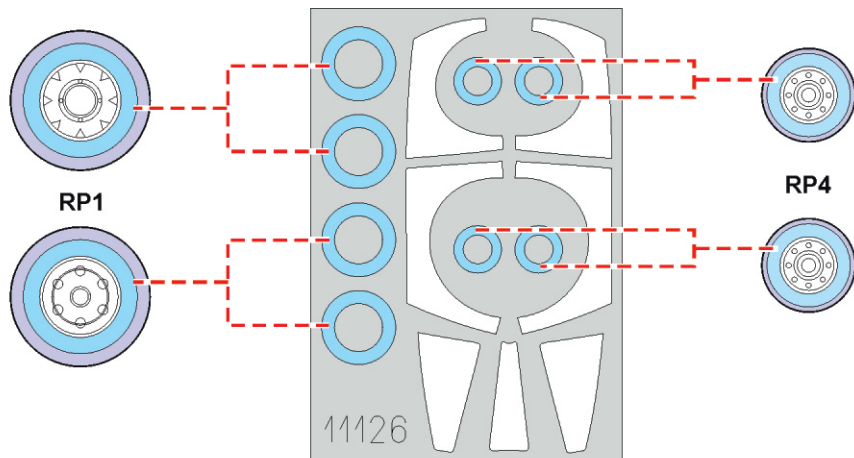
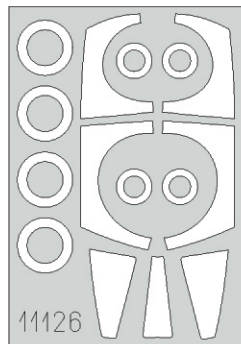

2.) LIQUID MASK

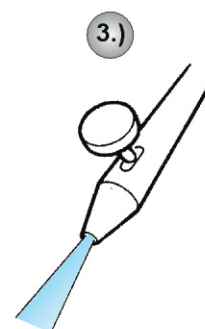
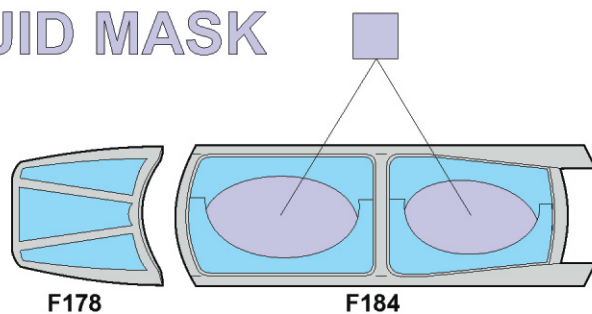

A ZG757, 43. squadrona, RAF Station Leuchars, Velká Británie, 2006

Jedním ze speciálních zbarvení, poukazujících na tradici jednotky trvající již od 1. světové války, se pyšnil letoun od 43. squadrony v celočerném lesklém kabátě, se znakem jednotky na kýlovce k 90. výročí založení útvaru. Později byla černá barva odstraněna z přídě a následující rok zůstaly v černé barvě pouze hřbet trupu a svislá ocasní plocha.

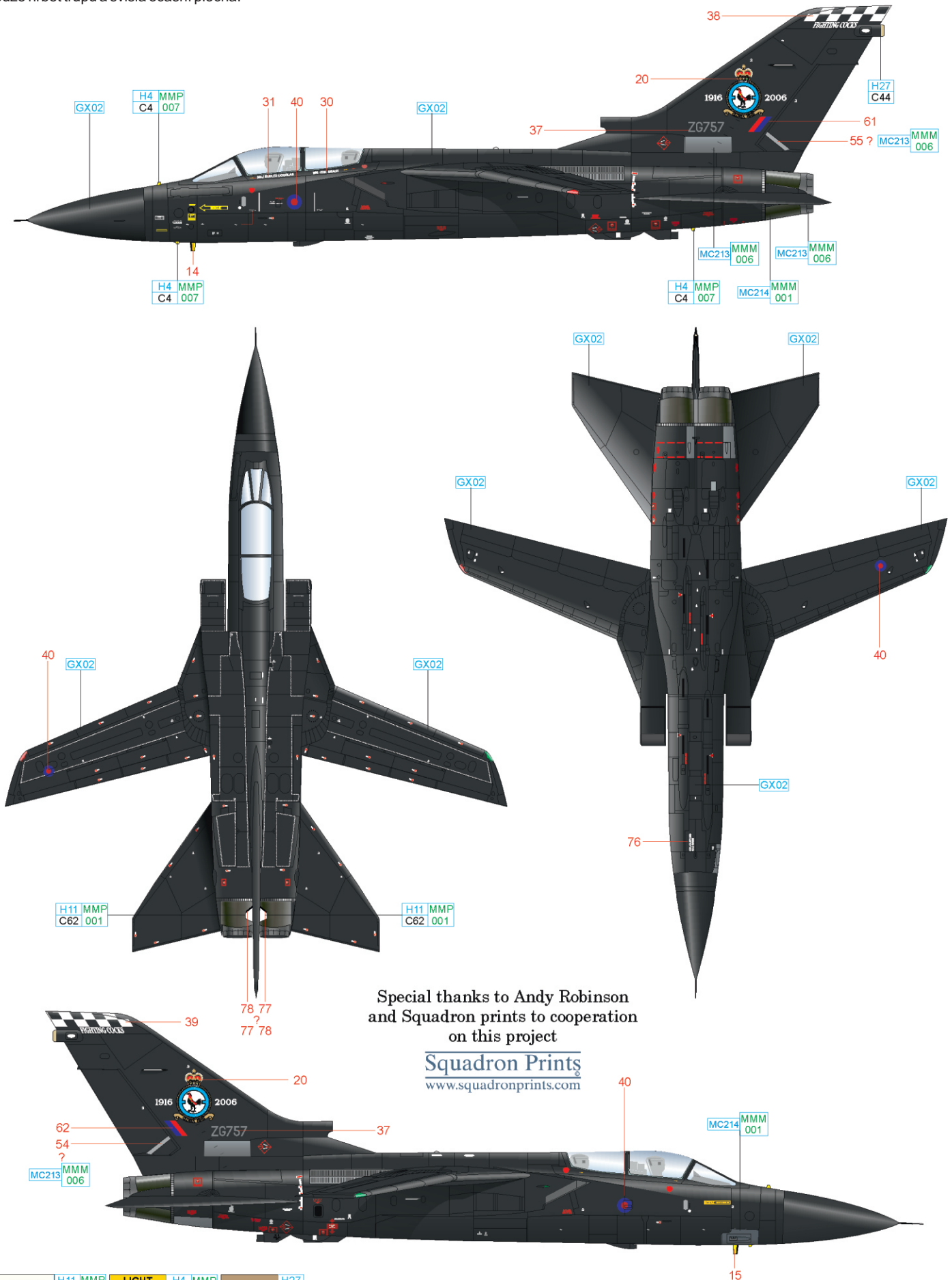

Special thanks to Andy Robinson and Squadron prints to cooperation on this project

Squadron Prints
www.squadronprints.com

WHITE	H11 MMP C62 001	LIGHT YELLOW	H4 MMP C4 007	TAN	H27 C44
STEEL	MC213 MMM 006	DARK IRON	MC214 MMM 001	BLACK	GX02

B ZE339, 56. squadrona, RAF Coningsby, Velká Británie, 2000

56. squadrona, jednotka s tradicí sahající až do léta 1916, v jejíž výzbroji byly od roku 1976 Phantomy FGR Mk.2, byla rozpuštěna k 1. červenci 1992. Jméno i tradice převzala 229. OCU, jednotka provádějící přeškolování osádek Tornad F.3. V roce 2000 byla kamufláž stroje ZE339 doplněna o atraktivní doplňky vztahující se k pojmenování jednotky (Firebirds). V roce 2008 byla 56. squadrona rozpuštěna a její jméno a tradice převzala jednotka AIR C2ISR OEU sídlící na základně Waddington a provádějící operační testování strojů Sentry AEW Mk.1, Sentinel R Mk.1 a všech používaných verzí strojů Nimrod.

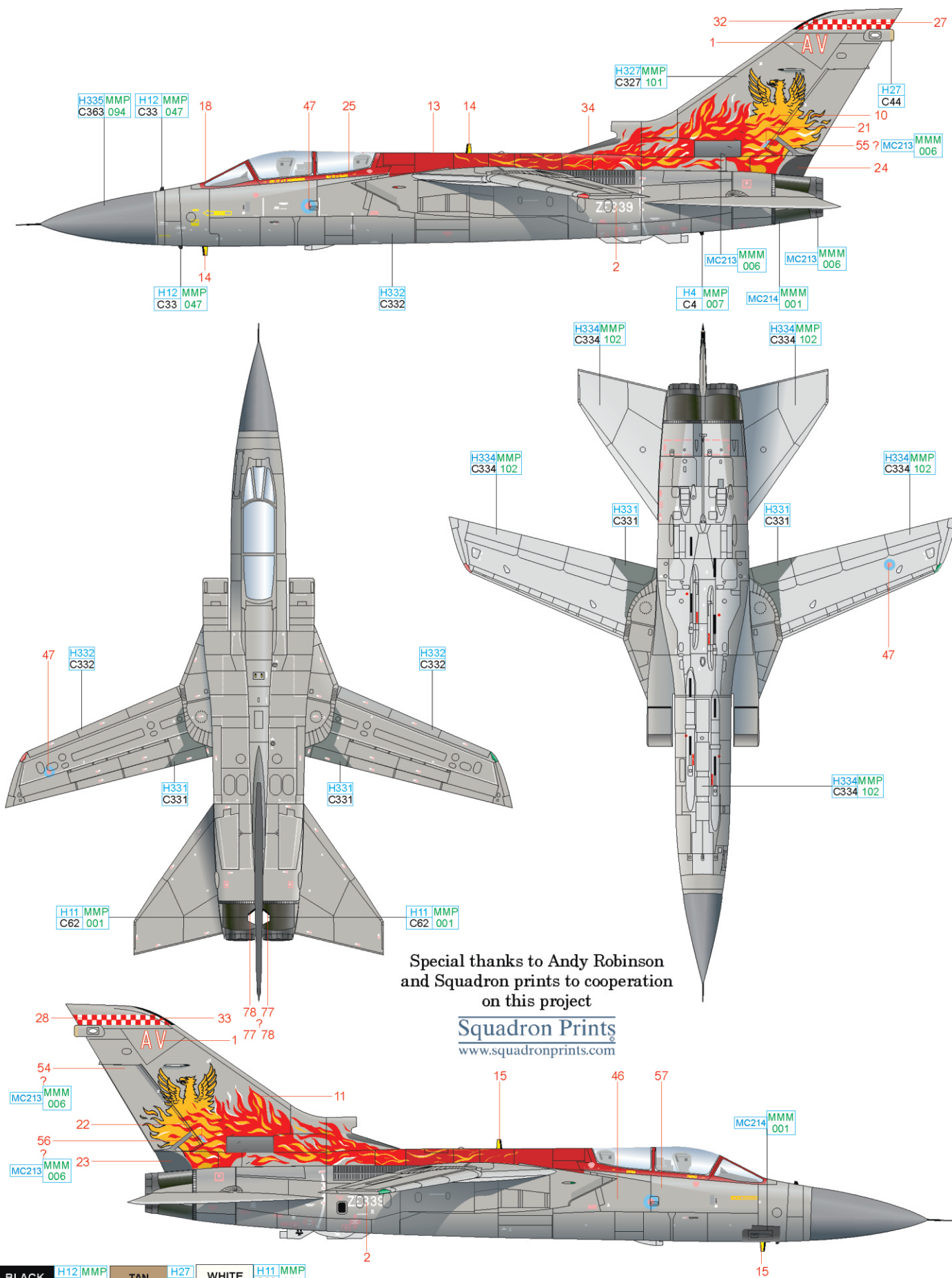

Special thanks to Andy Robinson and Squadron prints to cooperation on this project

Squadron Prints
www.squadronprints.com

BLACK	H12 MMP C33 047	TAN	H27 C44	WHITE	H11 MMP C62 001
BARLEY GRAY	H334 MMP C334 102	LIGHT AIR. GRAY	H332 C332	MEDIUM SEA GRAY	H335 MMP C363 094
				DARK SEA GRAY	H331 C331
				STEEL	MC213 MMM 006
					DARK IRON MC214 MMM 001

D ZG753, 111. squadrona, RAF Leuchars, Velká Británie, 2007

111. squadrona obdržela první Tornada F.3 jako náhradu za Phantomy FG.1 v roce 1989 a používala je až do 22. března 2011, kdy byla tato jednotka rozpuštěna. Stroji ZG753, vyrobeném v roce 1991, začal během přeletu z Falklandských ostrovů do Velké Británie, 500 km severně od ostrova Ascension, hořet jeden z motorů. Během nouzového přistání na tomto ostrově utrpěl stroj poškození, byl převezen zpět do Velké Británie a po prohlídce určen na náhradní díly. Jméno O Bandeirante bylo u "Treble One" poprvé použito v roce 1942. Objevilo se na Spitfiru jako výraz vděku Brazilcům a v Brazílii žijícím britským občanům, kteří dali finanční prostředky na zakoupení Spitfirů pro RAF.

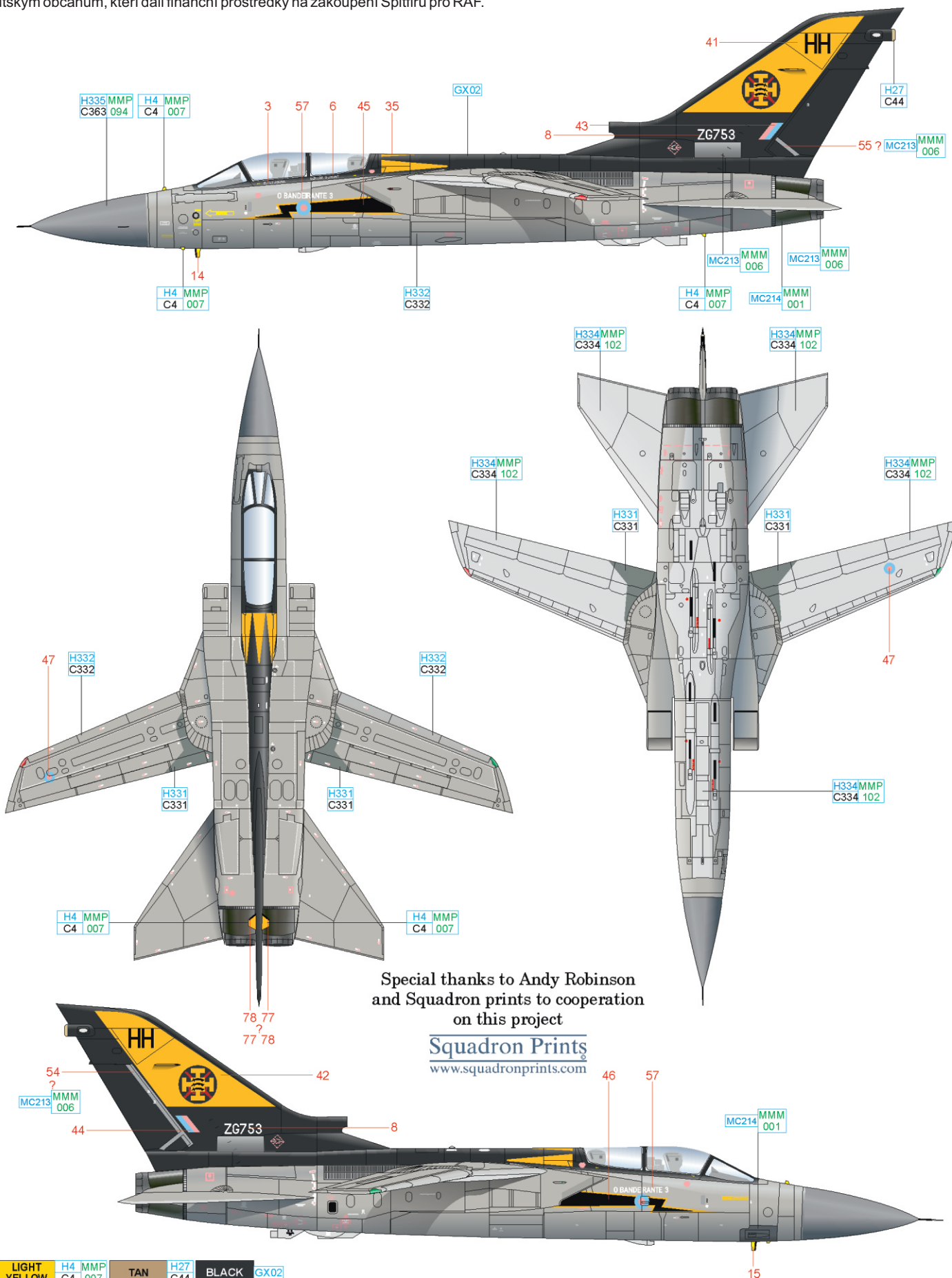

Special thanks to Andy Robinson and Squadron prints to cooperation on this project

Squadron Prints
www.squadronprints.com

LIGHT YELLOW	H4 MMP C4 007	TAN	H27 C44	BLACK	GX02
BARLEY GRAY	H334MMP C334 102	LIGHT AIR. GRAY	H332 C332	MEDIUM SEA GRAY	H335MMP C363 094
				DARK SEA GRAY	H331 C331
				STEEL	MC213 MMM 006
					DARK IRON MC214 MMM 001

E ZE785, Operational Evaluation Unit, RAF Waddington, Velká Británie, 2003

Vyhodnocování výkonů a používání zbraní a systémů u strojů Tornado F.3 probíhalo od roku 1987 u OEU sídlící na základně Waddington. Činnost této jednotky usnadňovala zavádění strojů u bojových jednotek a během jejich provozování pak posuzování výkonů pokračovalo s cílem maximálního využití jejich schopností. Roku 2003 padlo rozhodnutí rozpuštění OEU v roce následujícím. ZE785 pak posloužil jako nosič atraktivního zbarvení vytvořeného právě k příležitosti ukončení činnosti OEU.

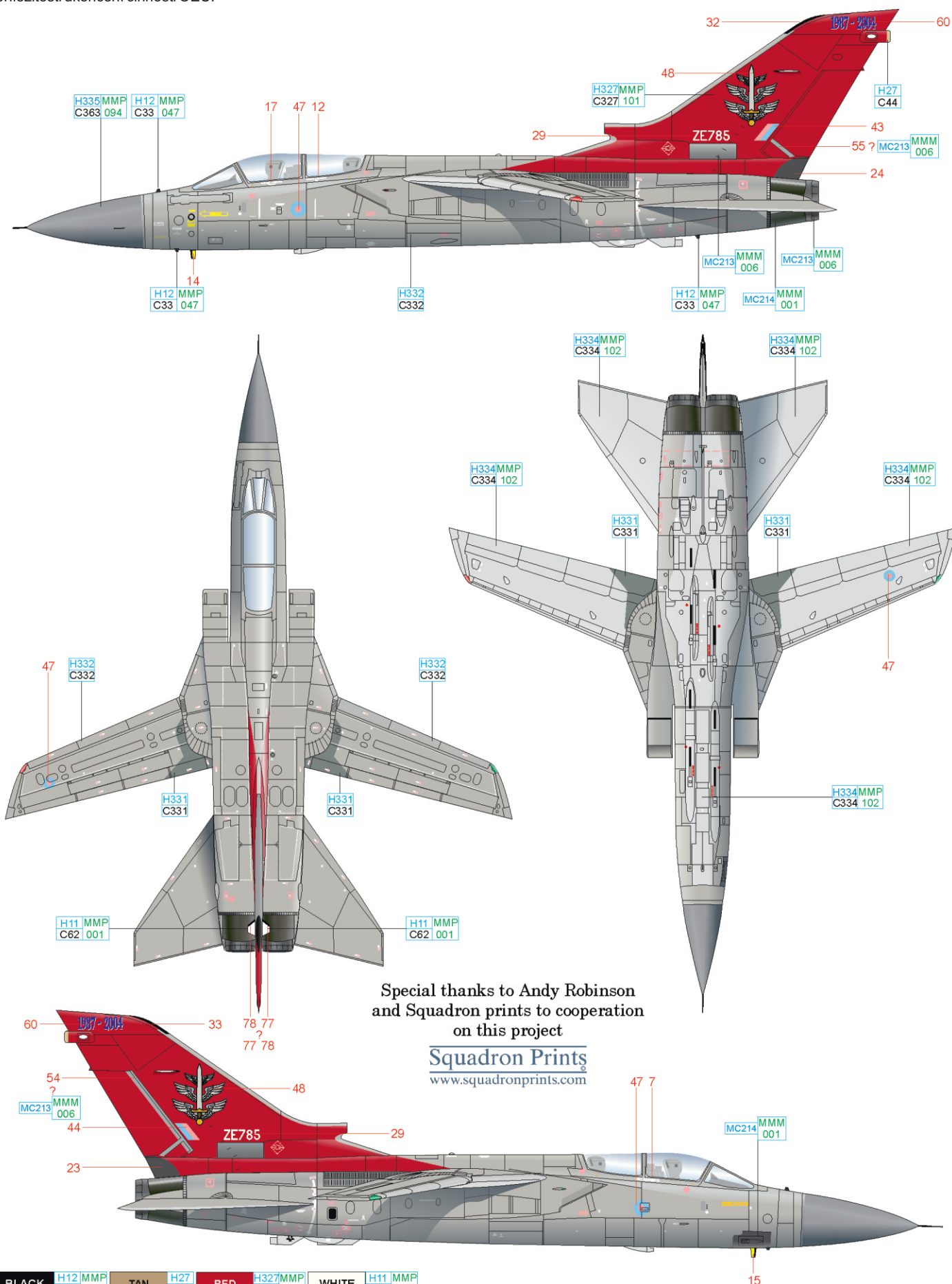

Special thanks to Andy Robinson and Squadron prints to cooperation on this project

Squadron Prints
www.squadronprints.com

BLACK	H12 MMP C33 047	TAN	H27 C44	RED	H327 MMP C327 101	WHITE	H11 MMP C62 001
BARLEY GRAY	H334 MMP C334 102	LIGHT AIR. GRAY	H332 C332	MEDIUM SEA GRAY	H335 MMP C363 094	DARK SEA GRAY	H331 C331
						STEEL	MC213 MMM 006
							DARK IRON MC214 MMM 001

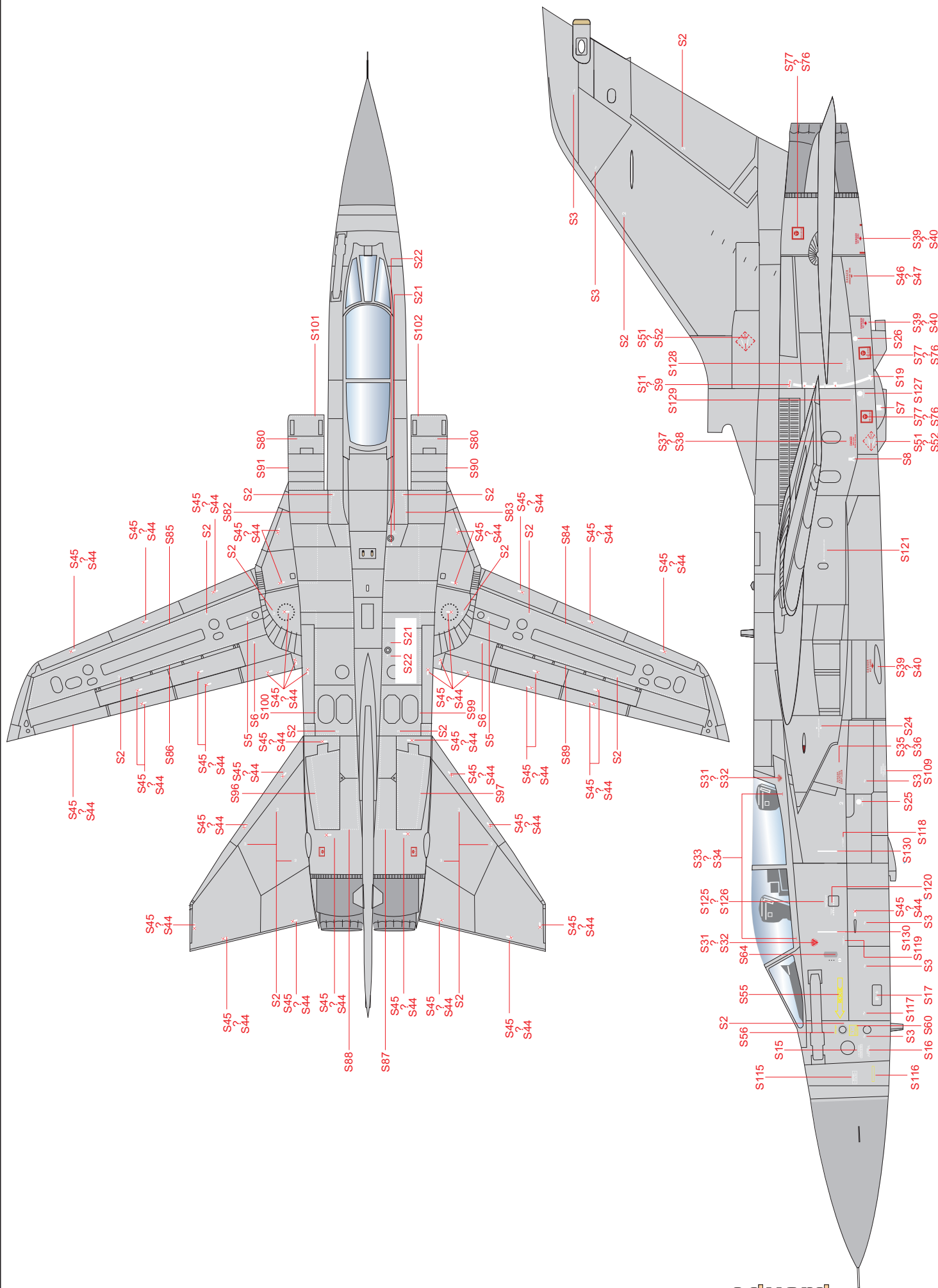

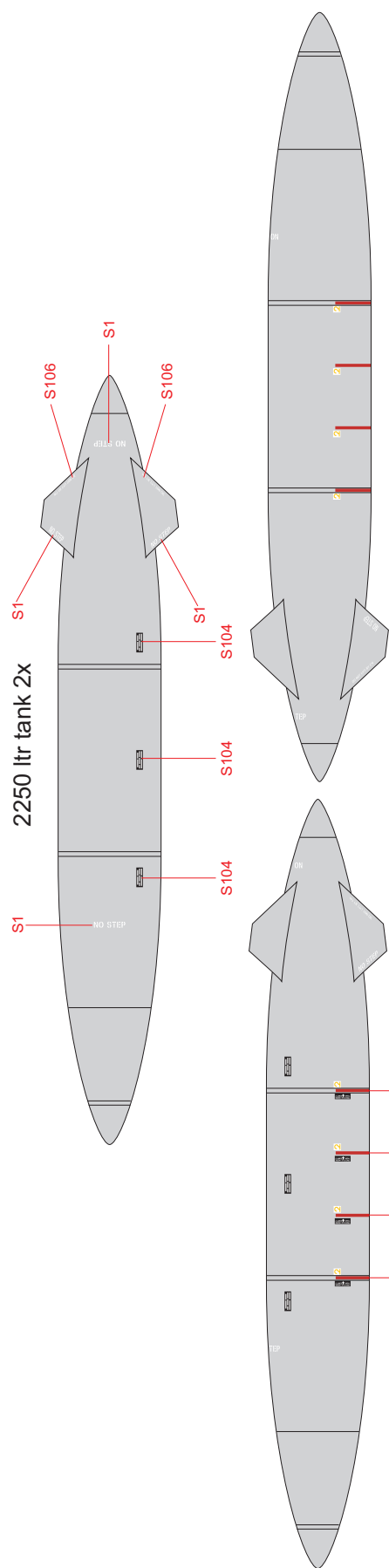

Right inboard wing pylon (outer face)

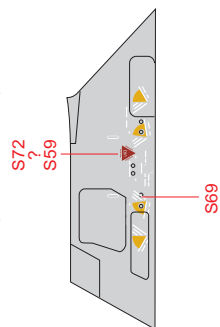

Right inboard wing pylon (inner face)

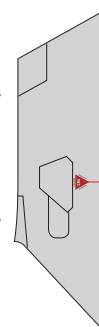

Left inboard wing pylon (outer face)

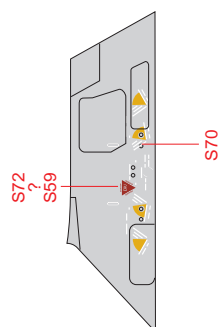

Left inboard wing pylon (inner face)

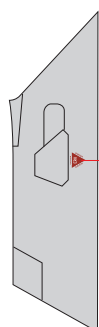

Sidewinder 4x

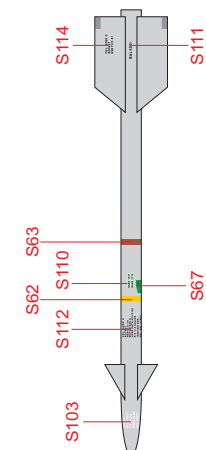

Skyflash 4x

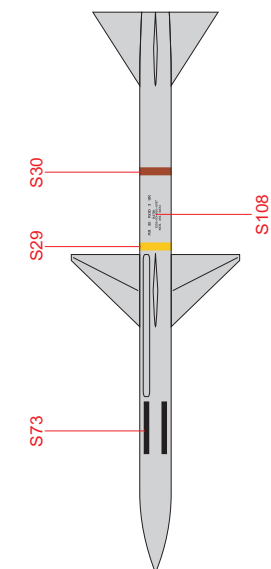

Sidewinder pylon 2+2

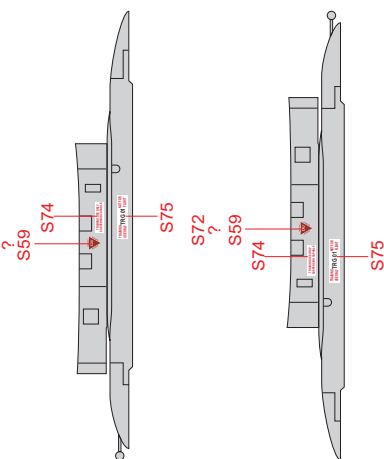

Tornado F.3 ADV

1/48

#11126

eduard
LIMITED EDITION

RELATED PRODUCTS for Tornado F.3 ADV:

- 48989 Tornado F.3 ADV upgrade set 1/48 (PE-Set)
- 49051 Remove before flight UK 1/48 (PE-Set)
- 49881 Tornado F.3 ADV undercarriage 1/48 (PE-Set)
- 648029 AIM-9M/L Sidewinder 1/48 (Brassin)
- 648084 AIM-120A/B AMRAAM (Brassin)
- EX575 Tornado F.3 ADV TFace 1/48 (Mask)

Cat. No. 49881

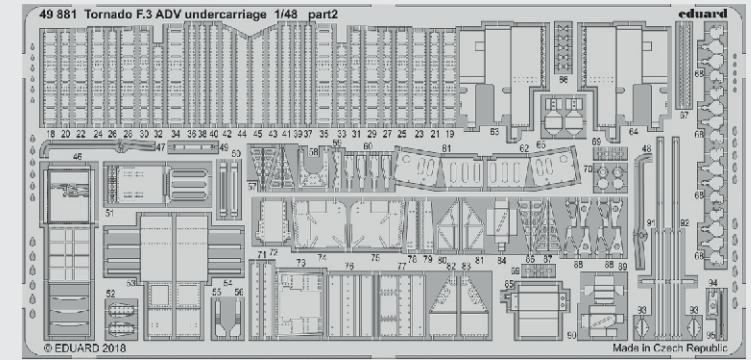
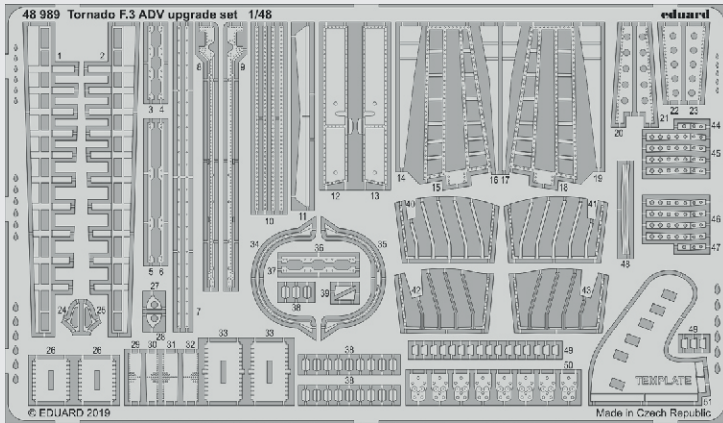
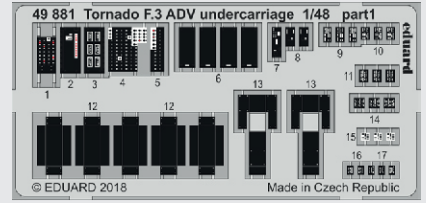

Cat. No. 49881

Cat. No. 48989

Cat. No. 648029

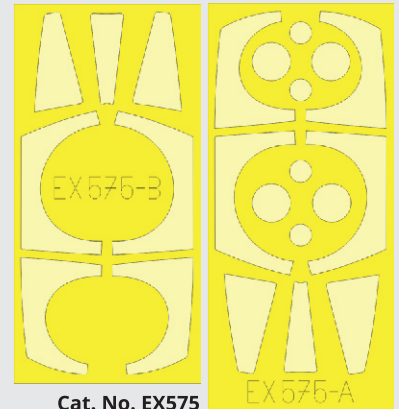
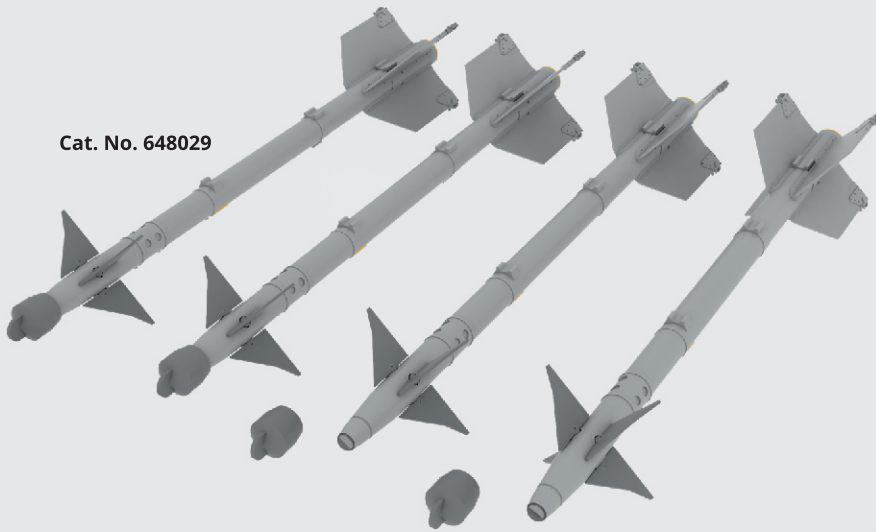

Cat. No. EX575

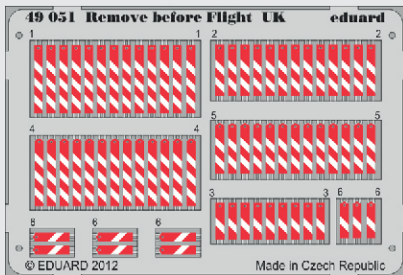

Cat. No. 49051

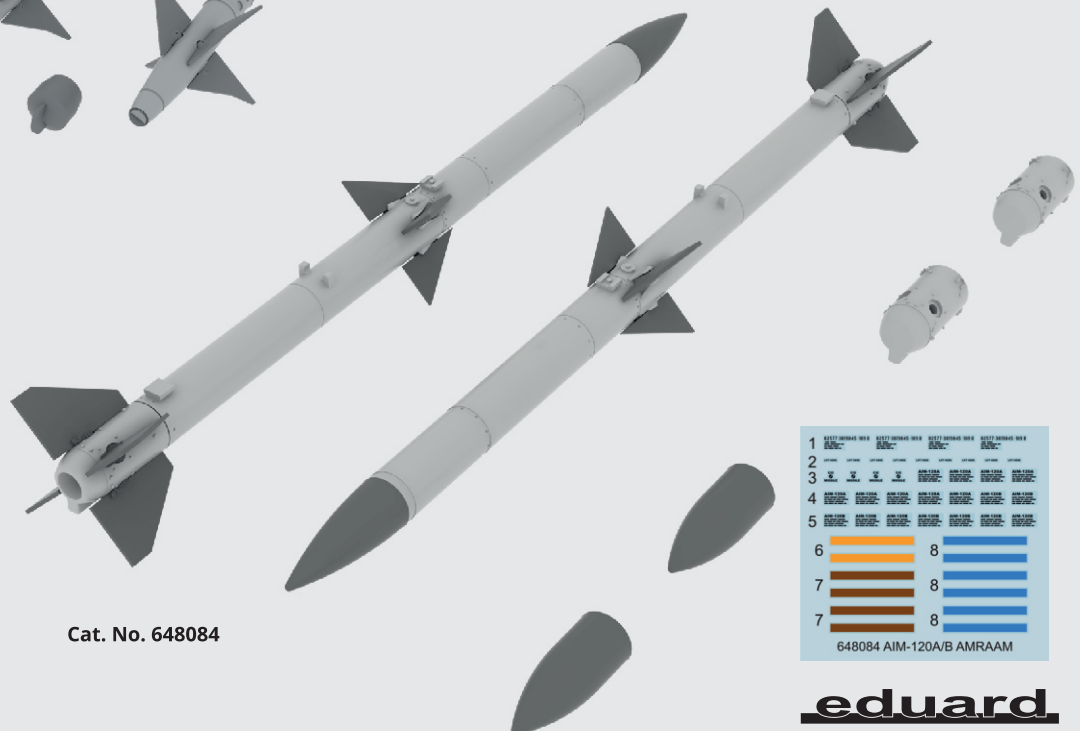

Cat. No. 648084

